

SPIKE Prime Basismodell

phobricks

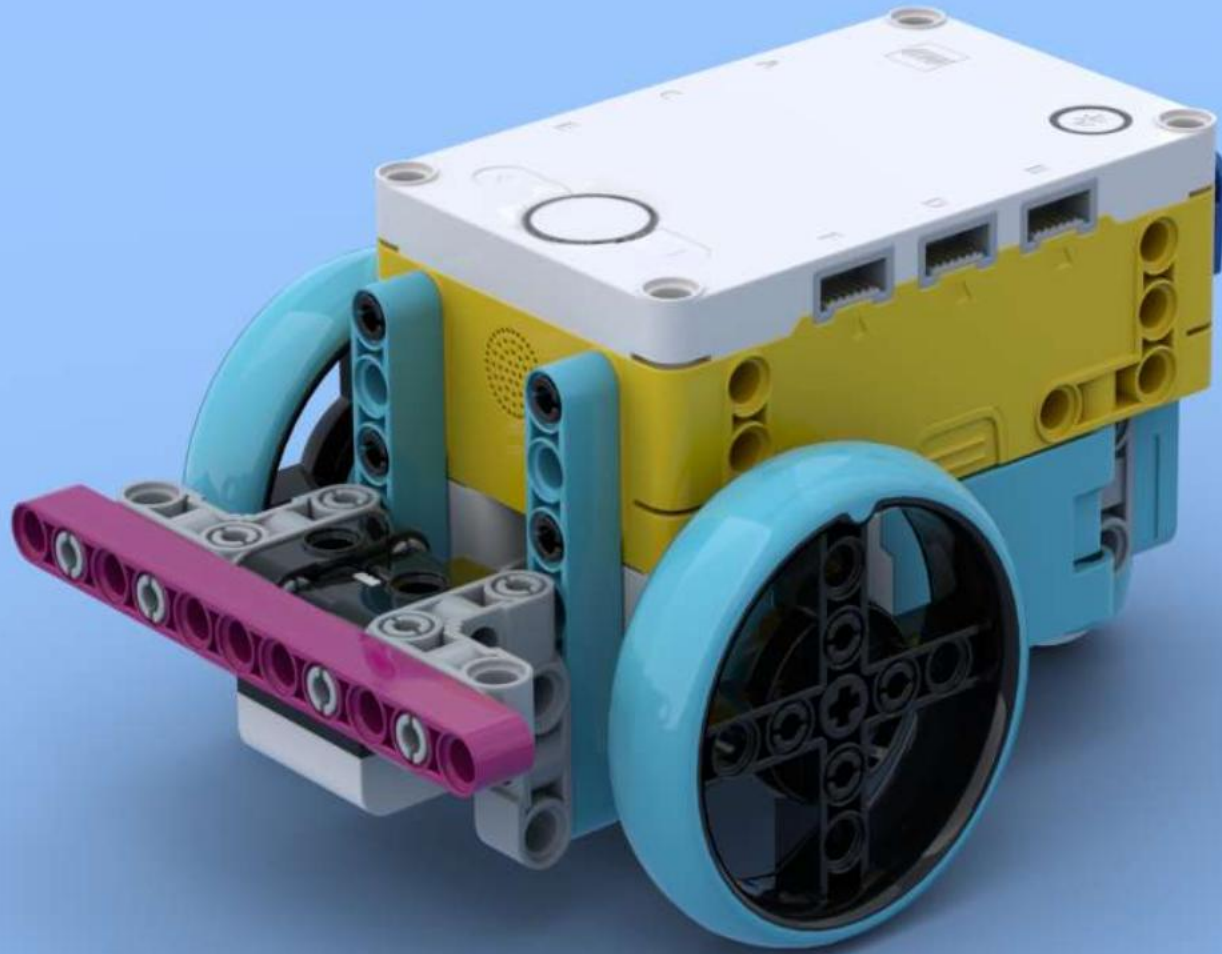

Frank Ellerkamp
<https://phobricks.ch>

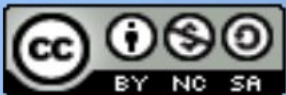

1

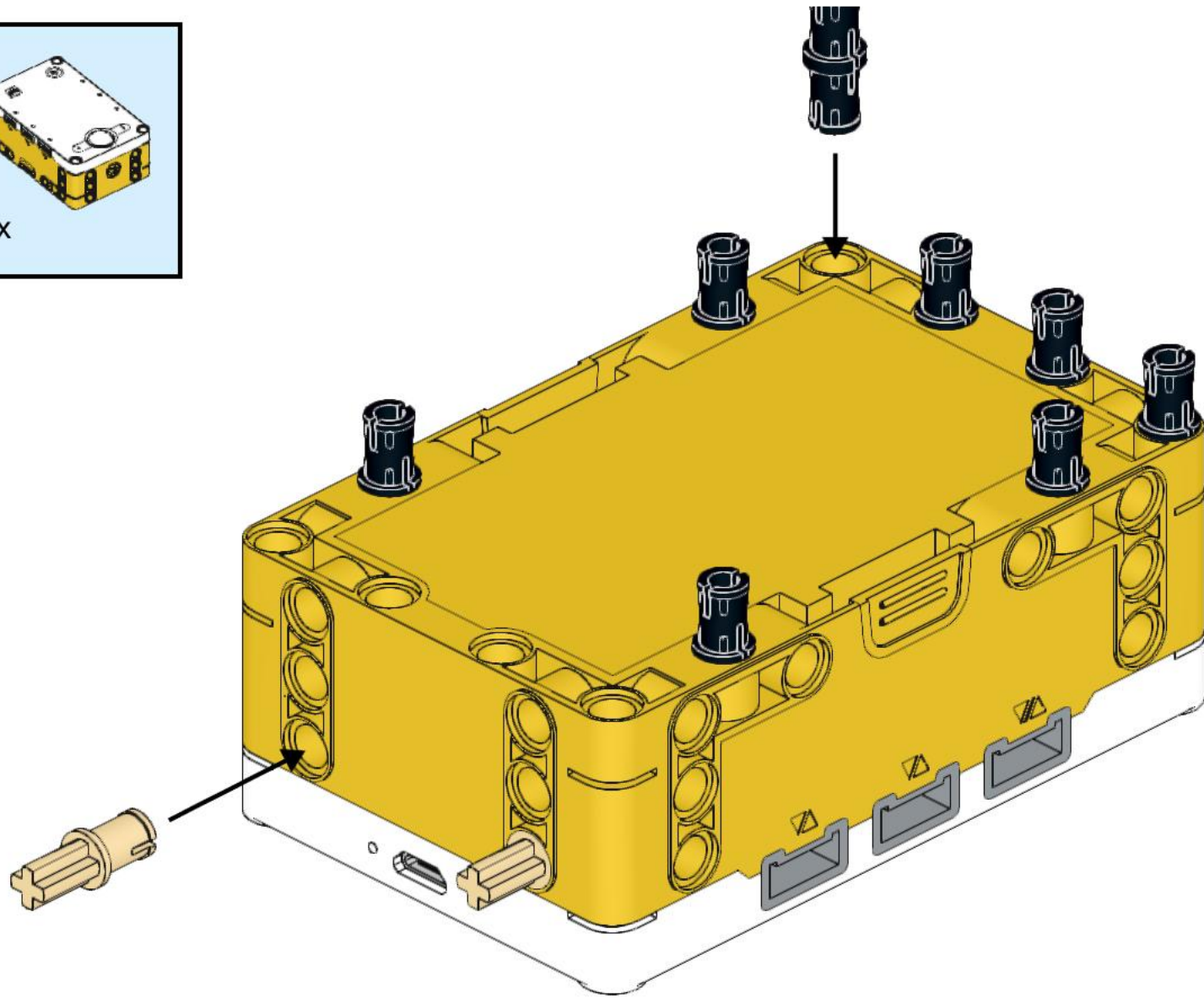
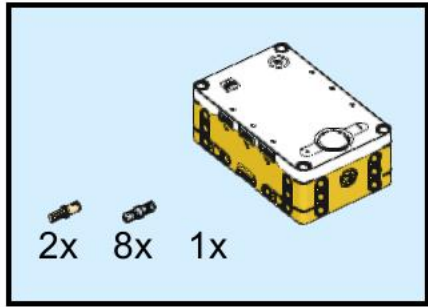

phobricks

2

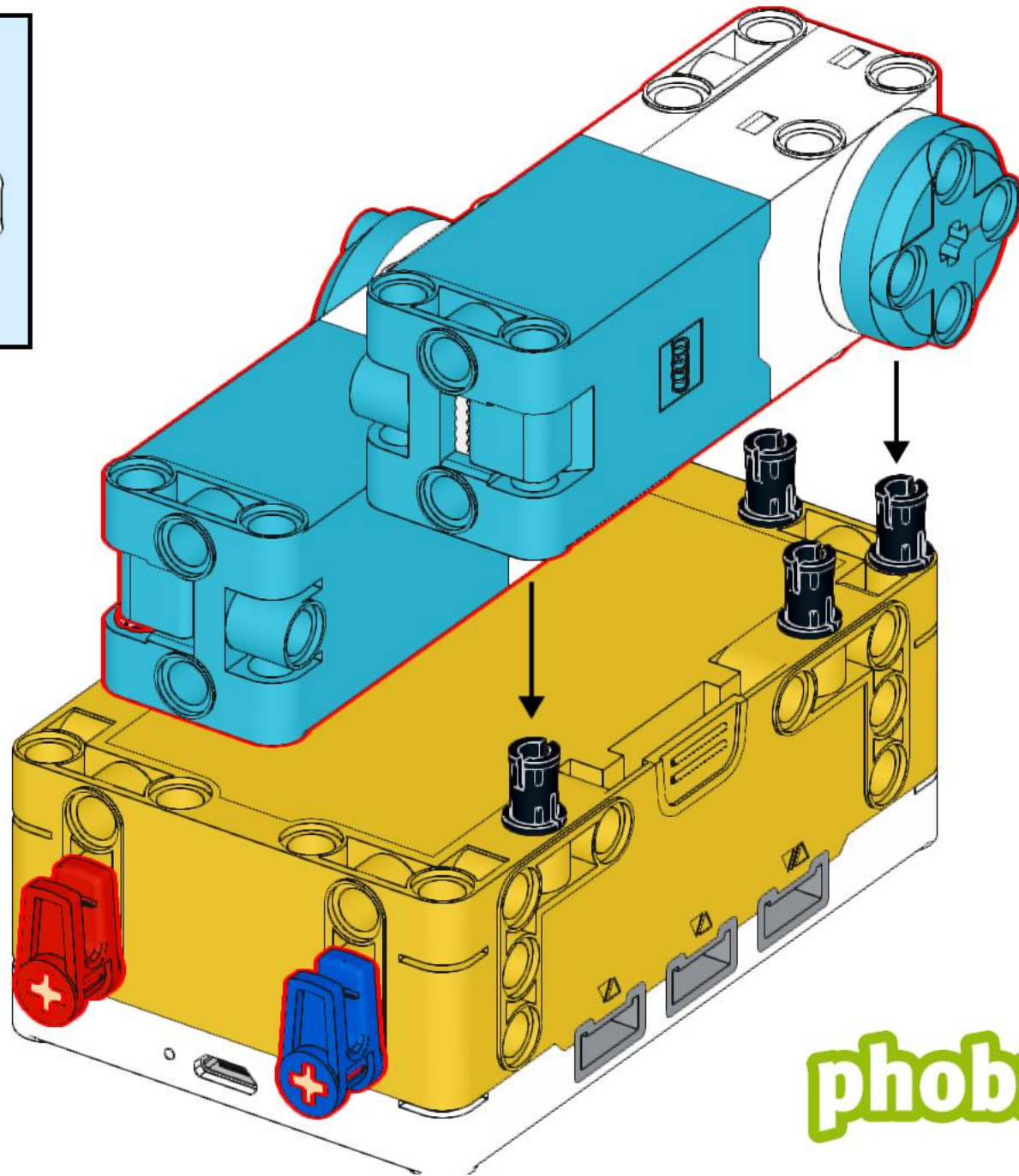
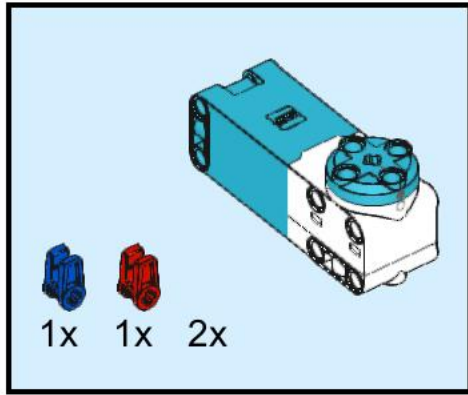

phobricks



3

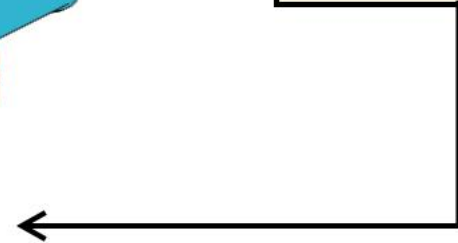
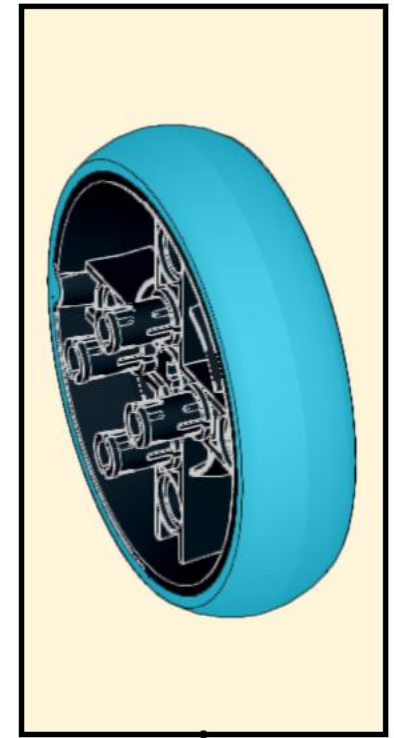
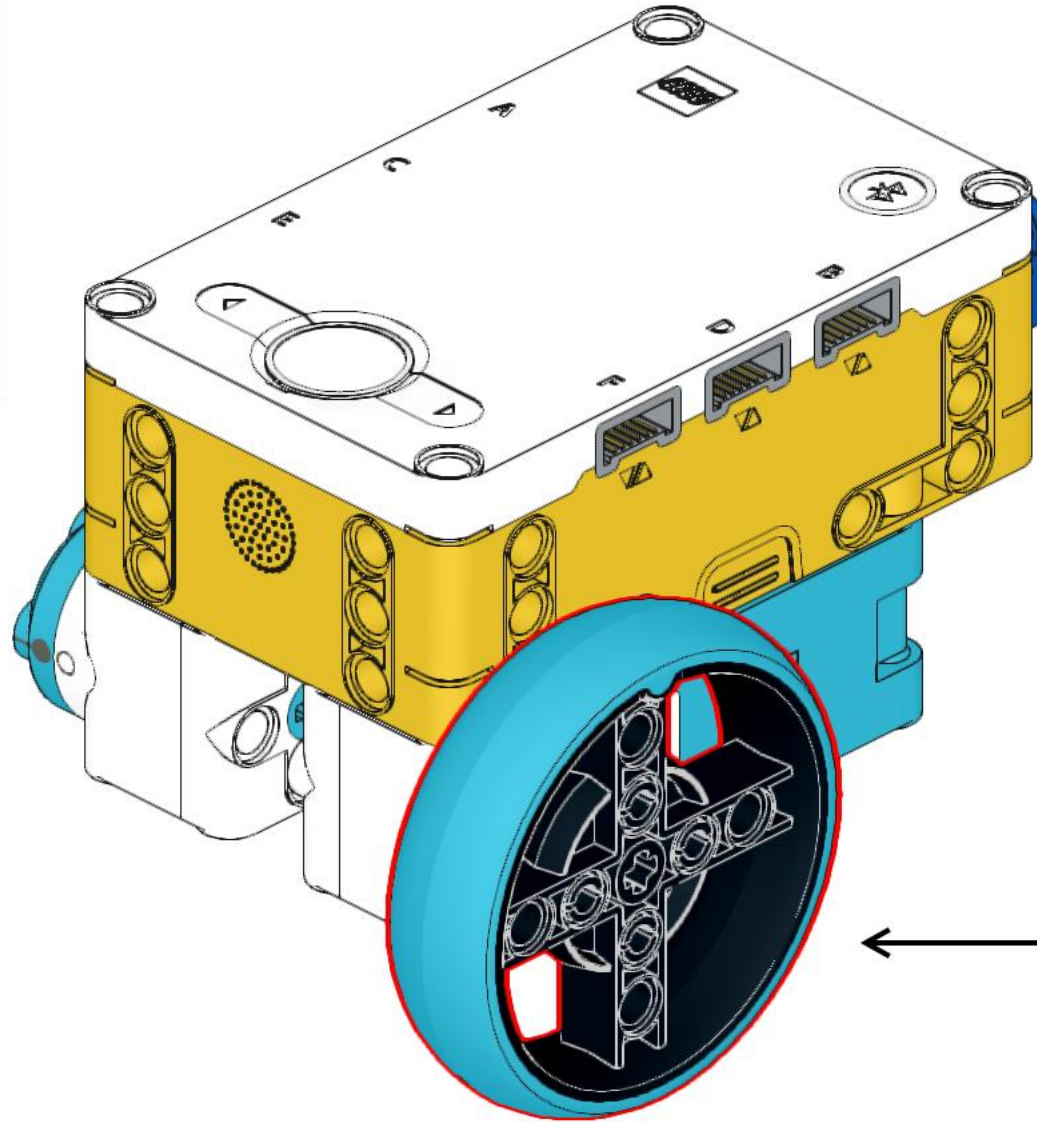
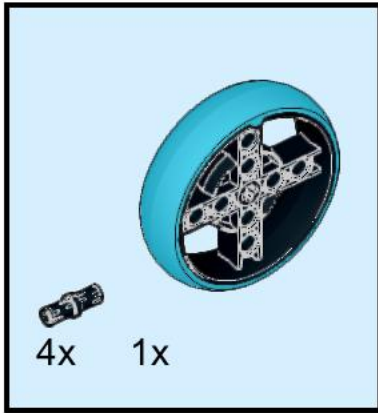

phobricks

4

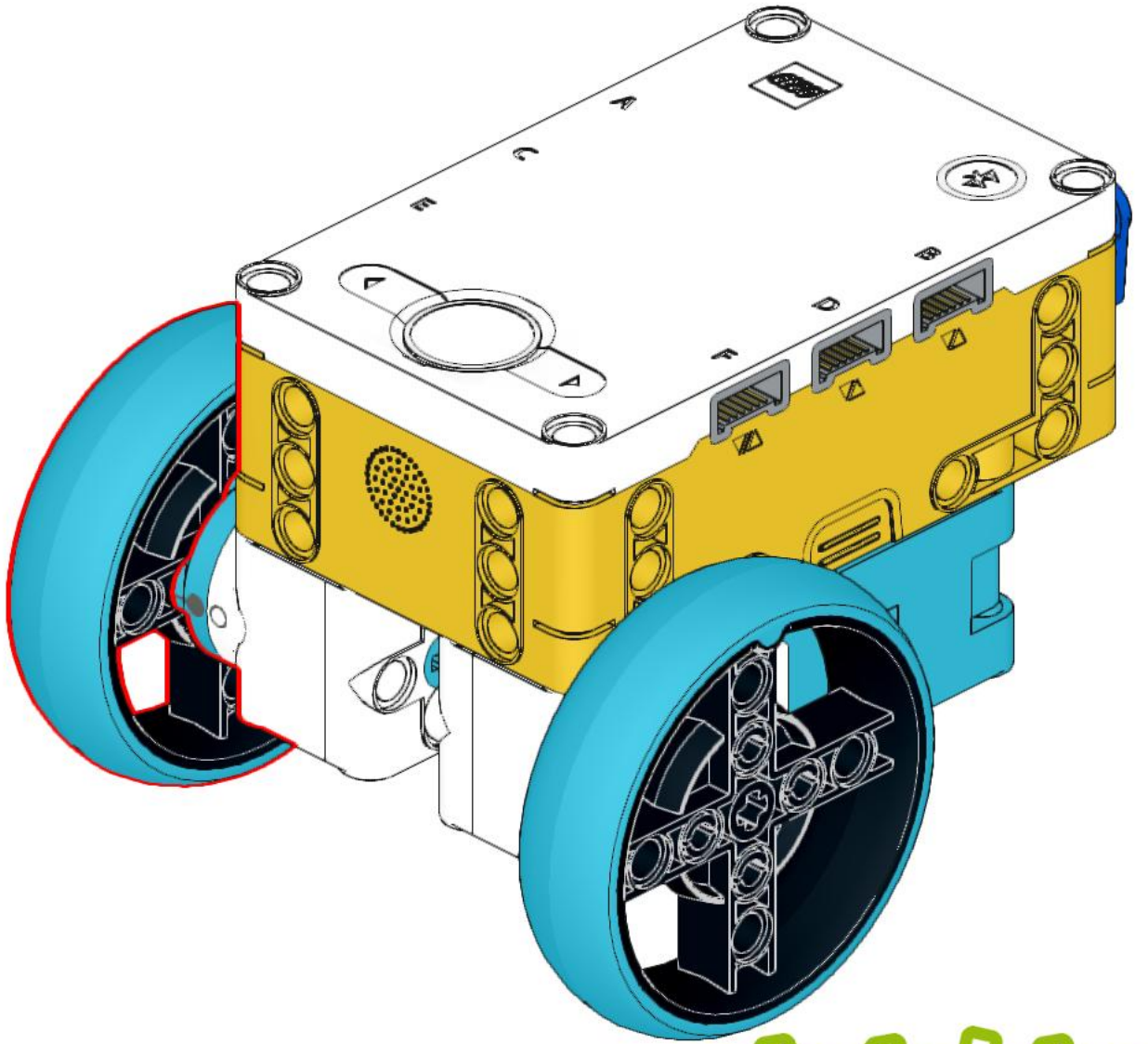
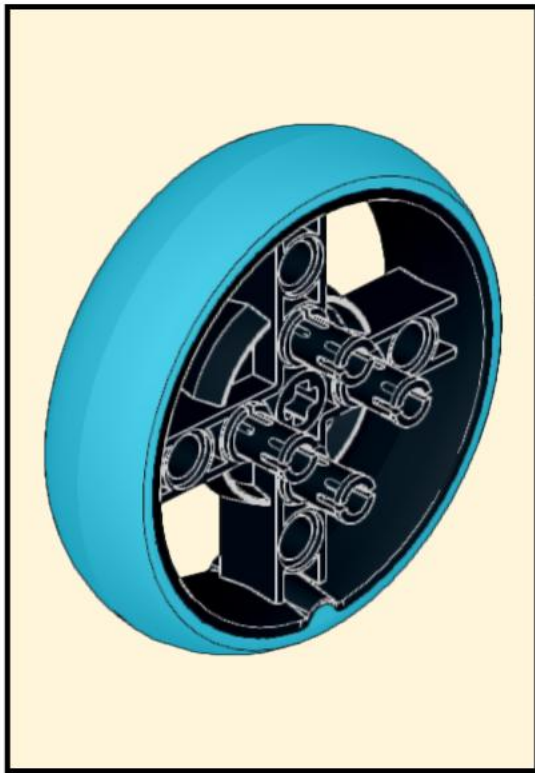
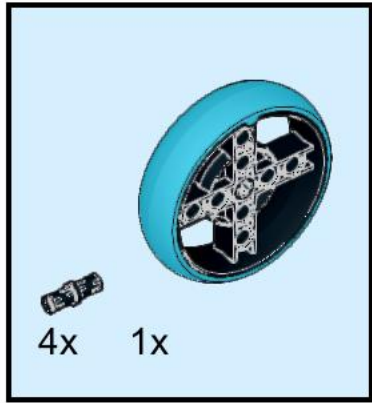

phobricks

5

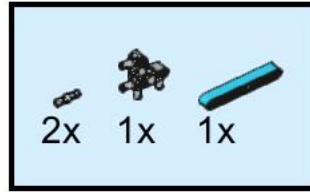
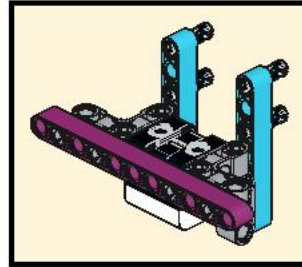
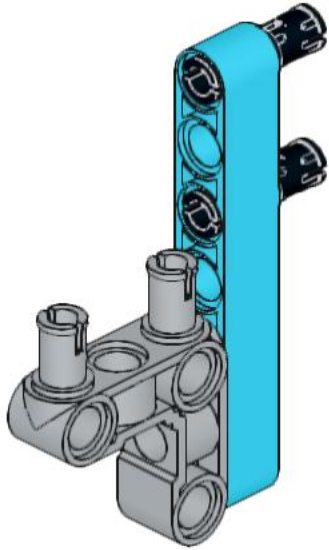

6

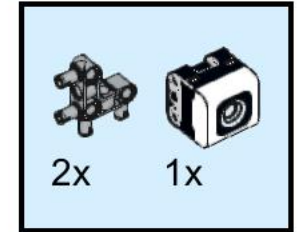
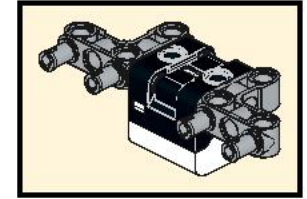
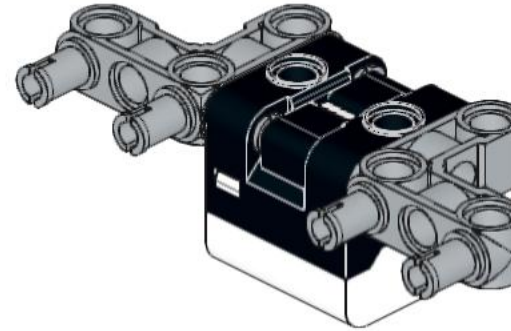

7

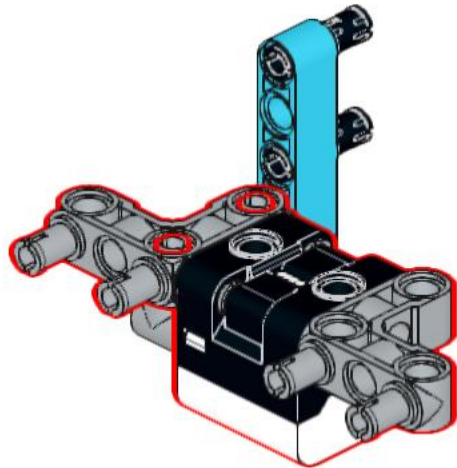

8

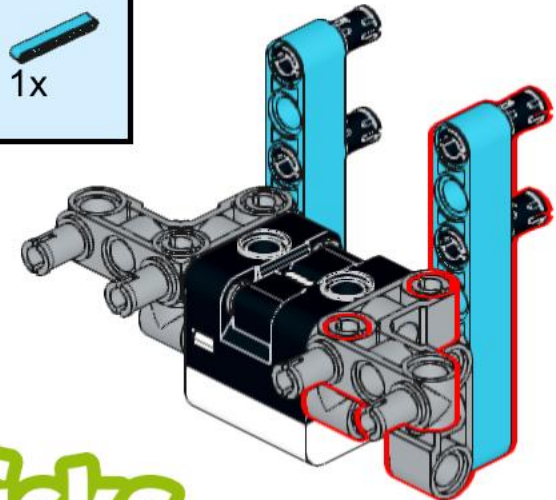
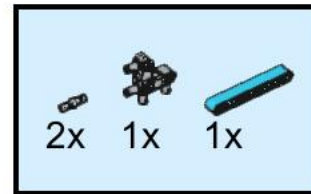

phobricks

9

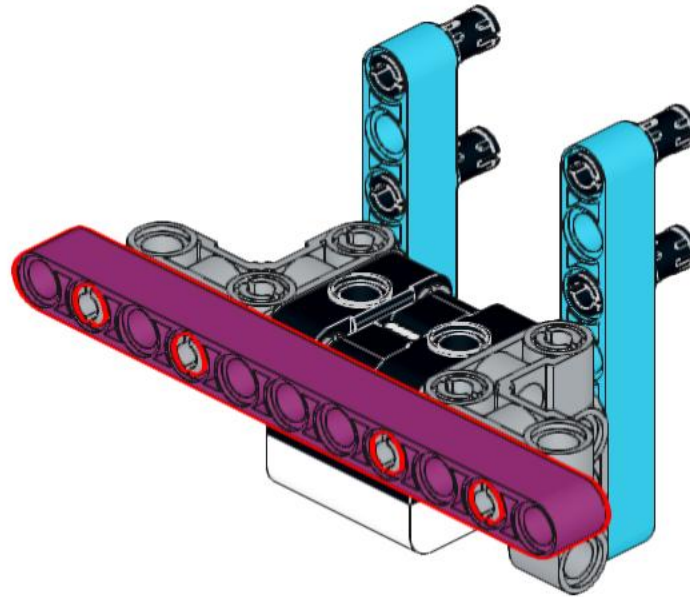
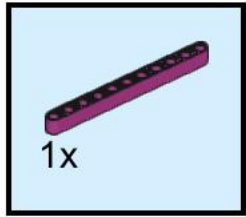

phobricks

10

Kabelführung



unter Hub

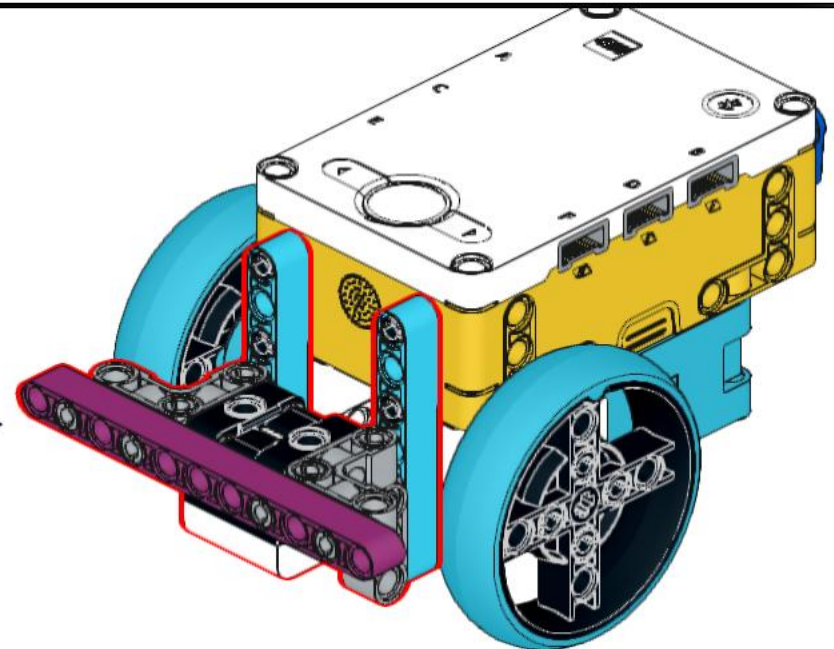

11

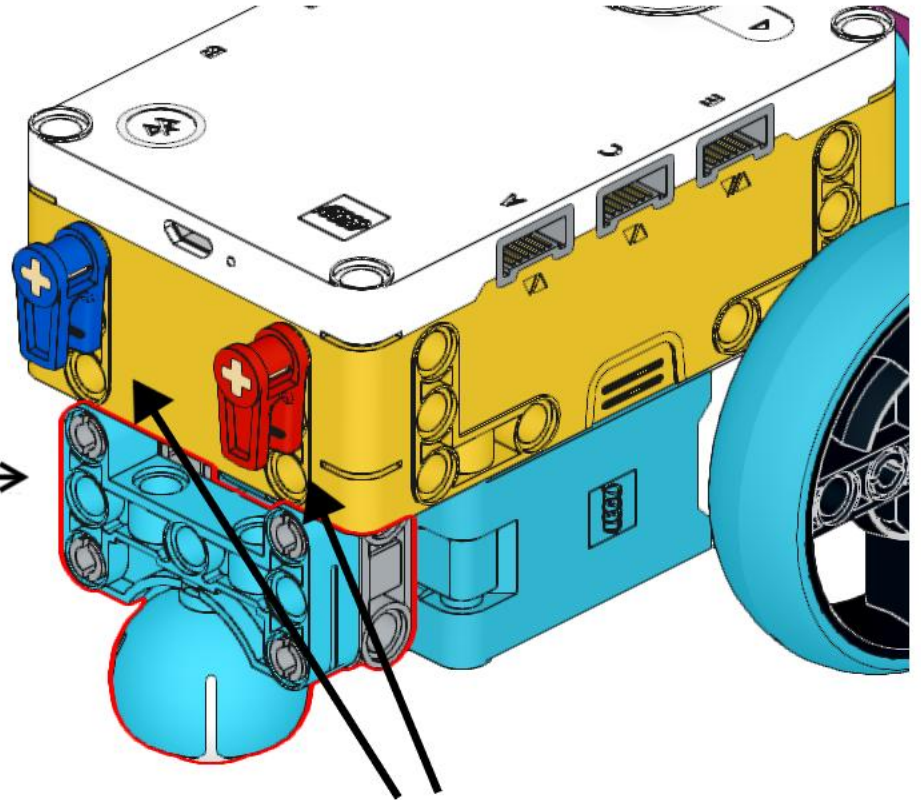
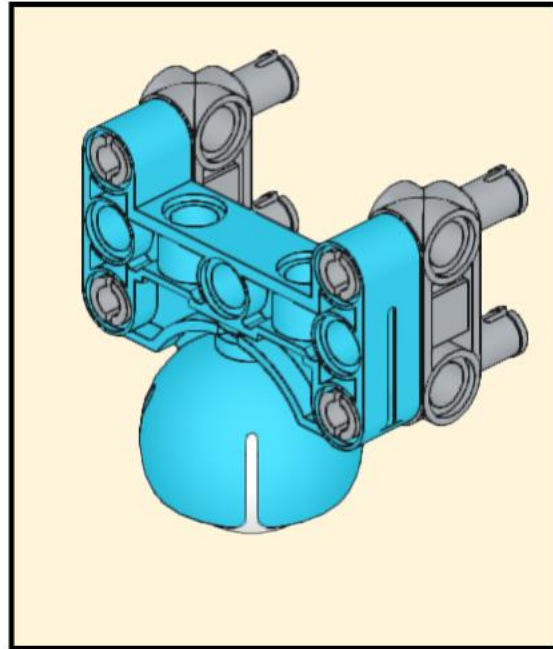
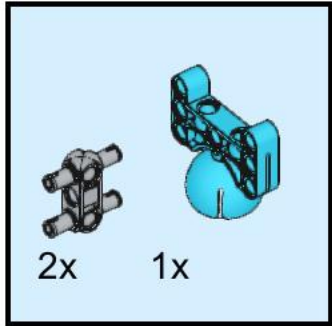

Kabelführung

Farbsensor

Clips für die beiden Motorenkabel

Motor links

Motor rechts

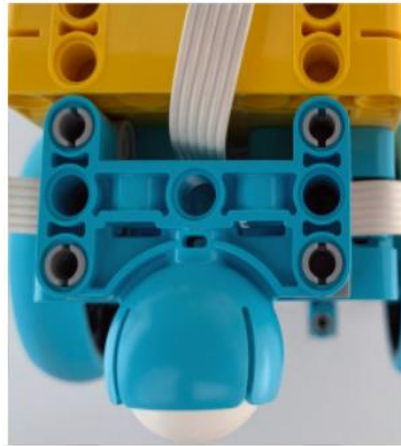

phobricks

Anschlüsse

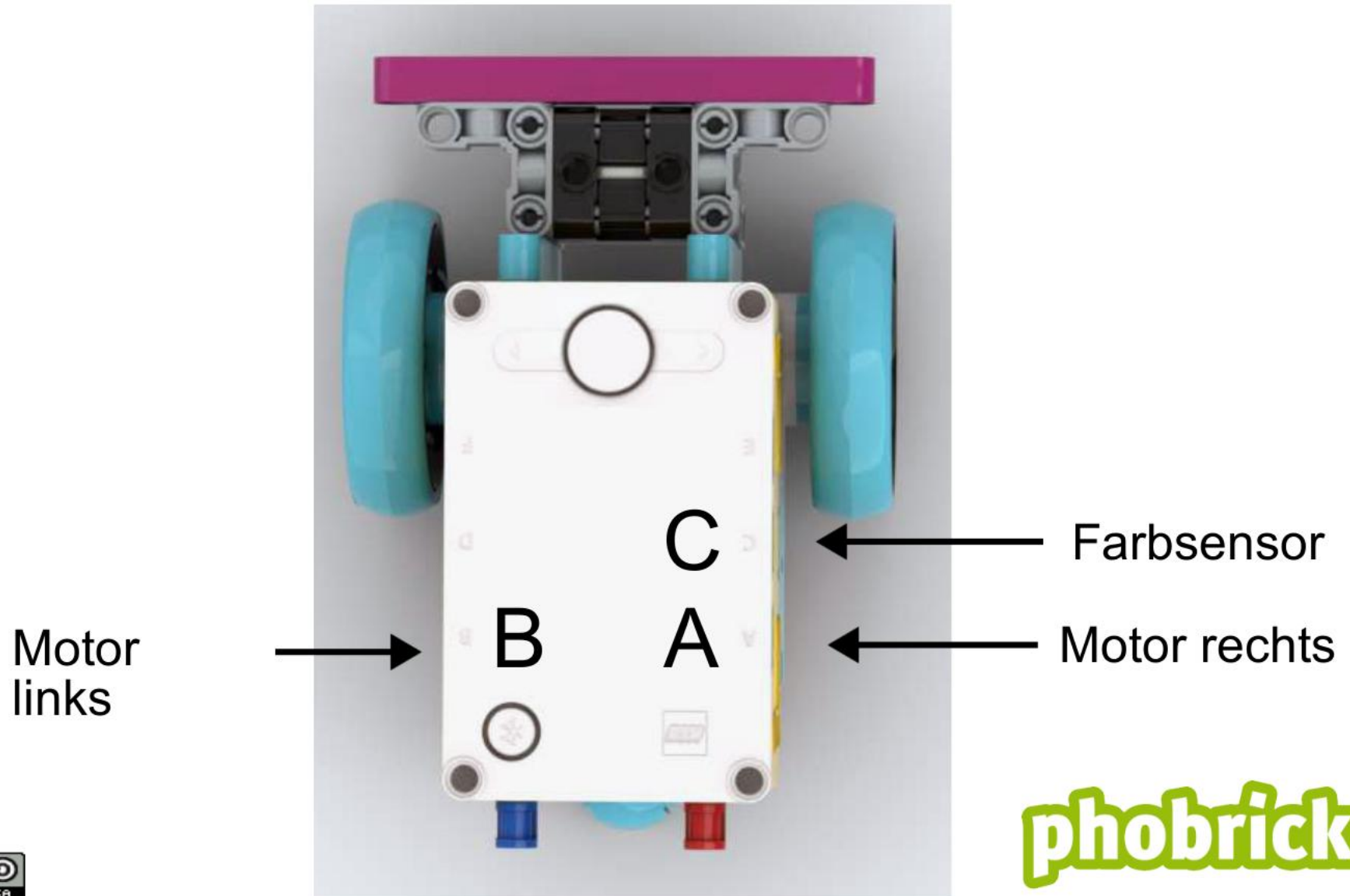

phobricks

Block-Programm "Bleib in der Arena"

The image shows a Scratch-style block programming environment with a grid background. The program starts with a yellow 'wenn das Programm startet' (when program starts) block. This is followed by two purple blocks: 'Antriebsmotoren Anschluss B+A zuweisen' (assign drive motors connection B+A) and 'Geschwindigkeit auf 50 % einstellen' (set speed to 50%). A large orange 'wiederhole fortlaufend' (repeat forever) loop contains an orange 'falls' (if) block. The 'falls' block has a camera icon, 'C' selected in a dropdown, 'ist die Farbe' (is the color), a black circle selected in a dropdown, and a question mark. Inside the 'falls' block, there are two purple blocks: '20 cm in folgende Richtung bewegen' (move 20 cm in the following direction) with a downward arrow selected, and '10 cm rechts: 70 bewegen' (move 10 cm right: 70). Below the 'falls' block is an orange 'sonst' (else) block containing a purple block 'in folgende Richtung starten geradeaus: 0' (start in the following direction straight ahead: 0). The 'wiederhole fortlaufend' loop ends with a curved arrow icon.

phobricks

Python-Programm "Bleib in der Arena"

```
1 from spike import PrimeHub, ColorSensor, MotorPair
2
3 myHub = PrimeHub()
4 myColorSensorC = ColorSensor('C')
5 myMotorPair = MotorPair('B', 'A')
6
7 while True:
8     color = myColorSensorC.wait_for_new_color()
9     if color == 'black':
10         myMotorPair.move(20, 'cm', 0, -50)
11         myMotorPair.move(10, 'cm', 70, 50)
12     else:
13         myMotorPair.start(0, 50)
```



phobricks