

SPIKE Prime Basismodell

phobricks

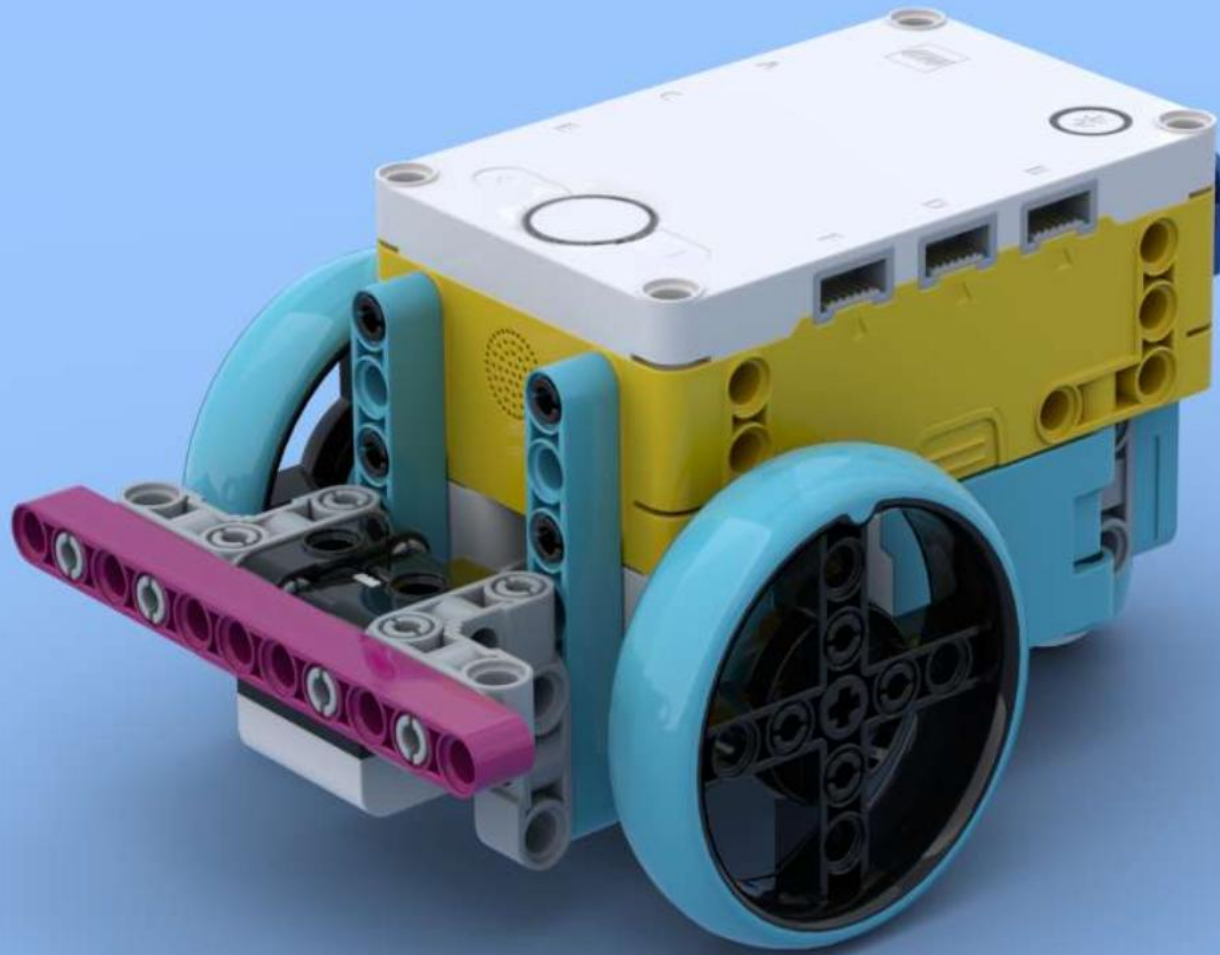

Frank Ellerkamp
<https://phobricks.ch>

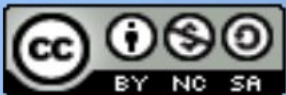

1

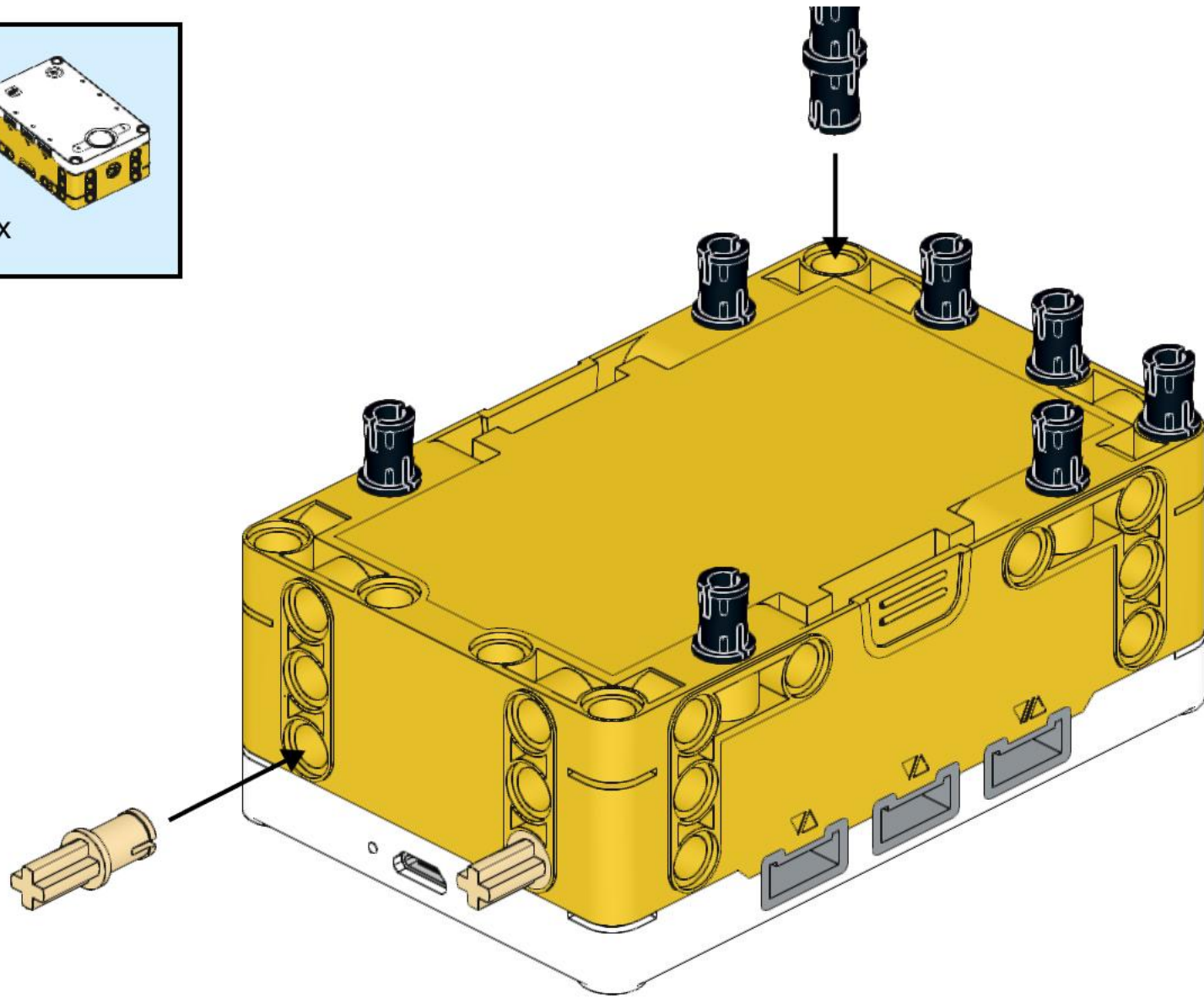
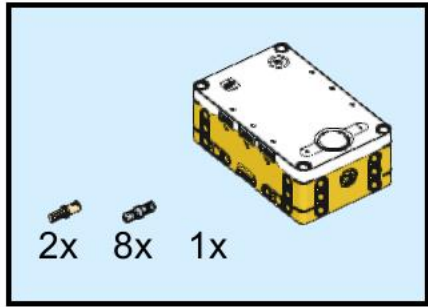

phobricks

2

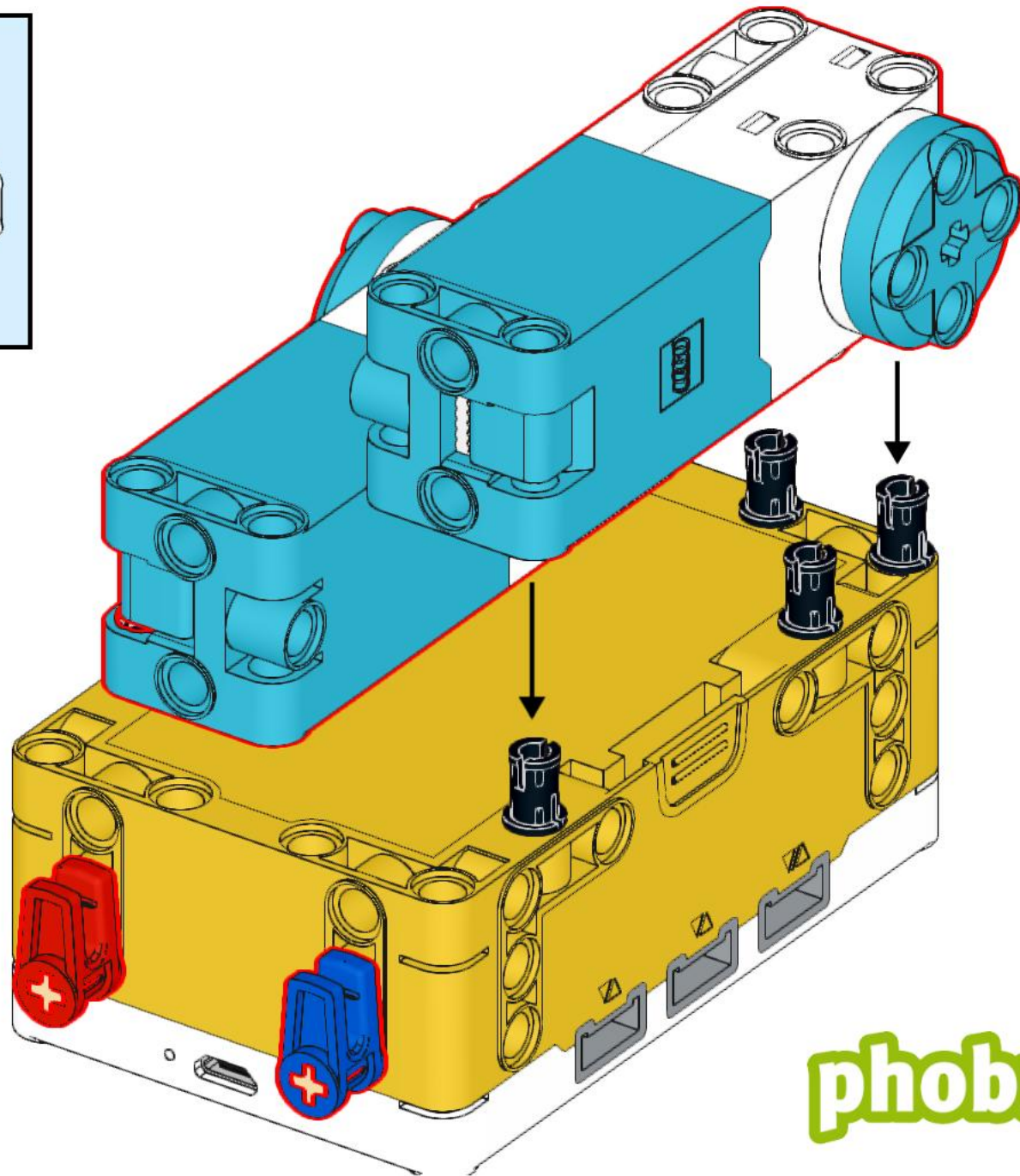
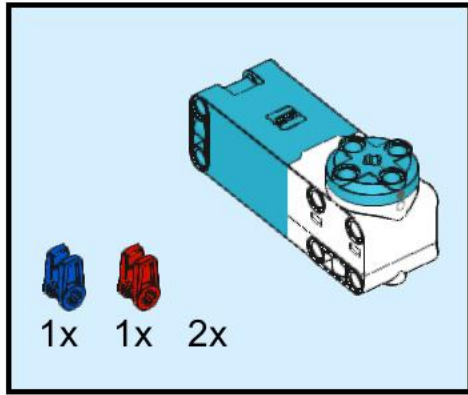

phobricks

3

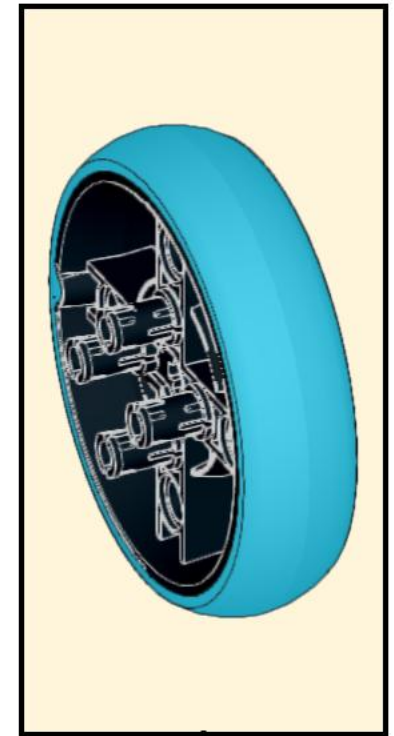
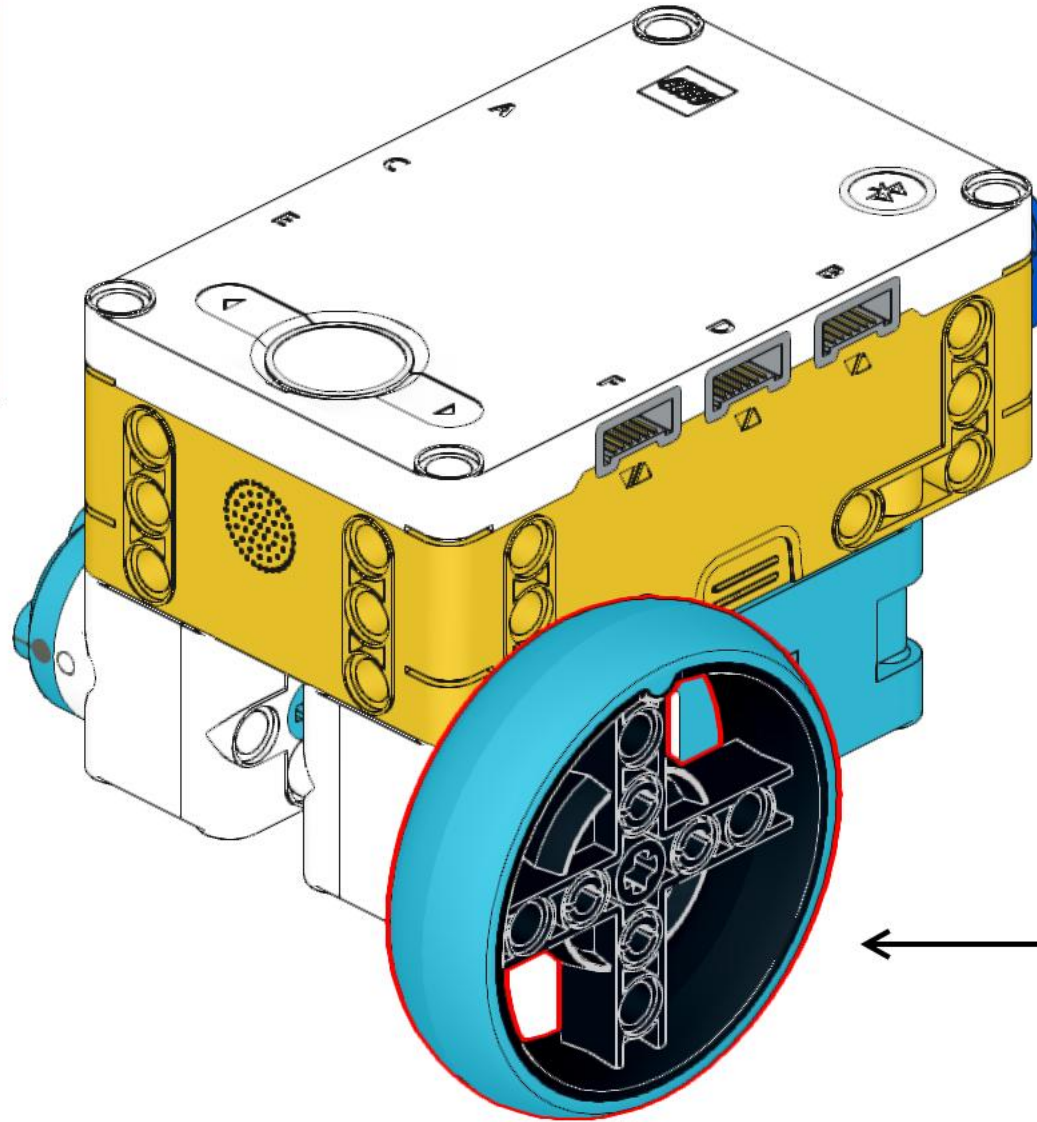
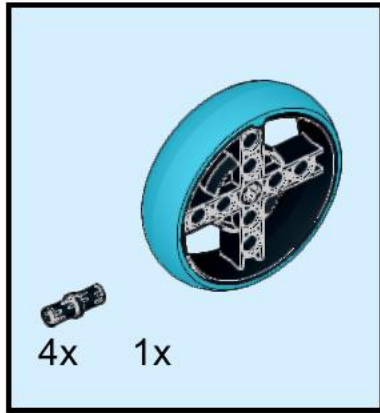

phobricks

4

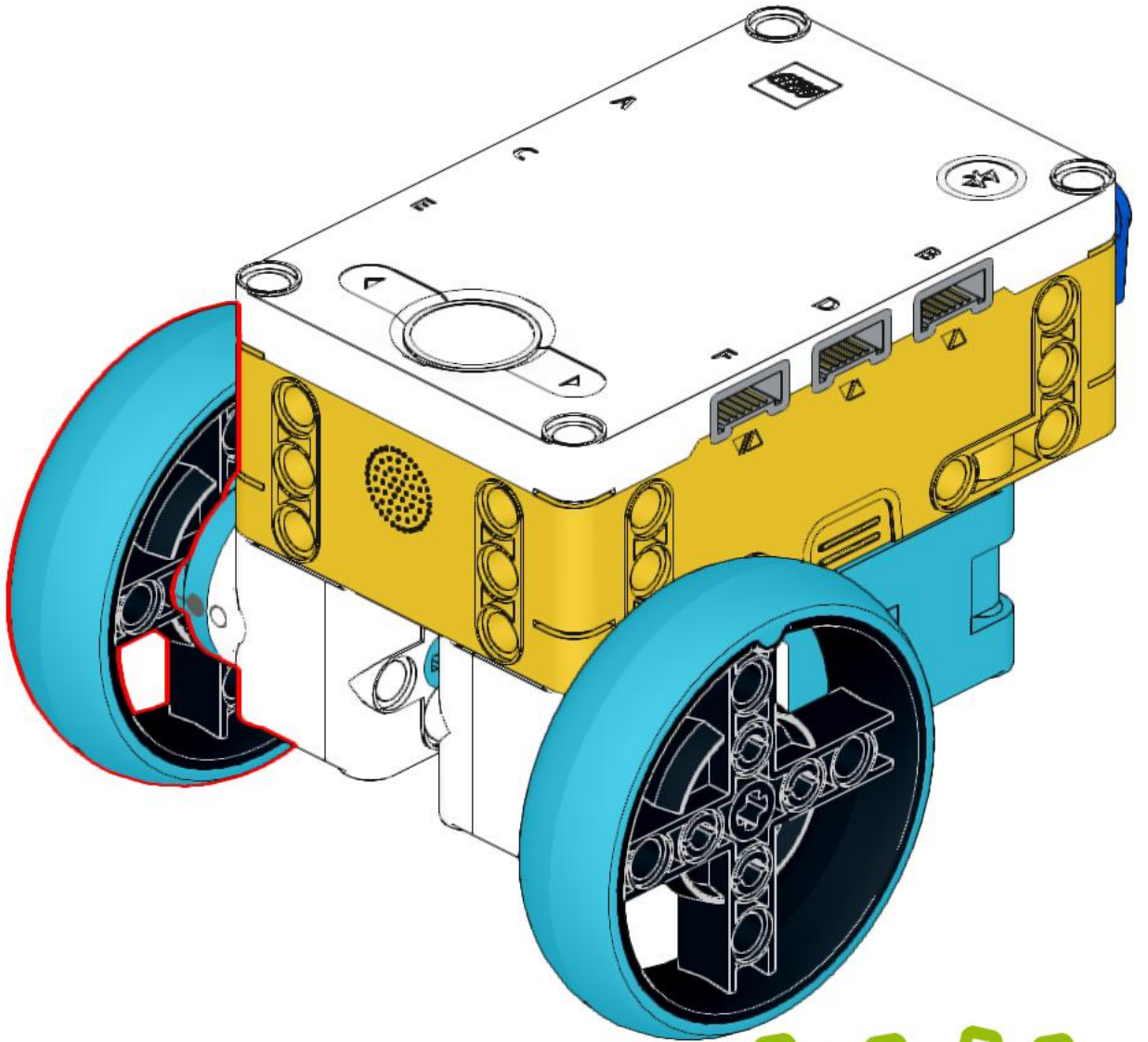
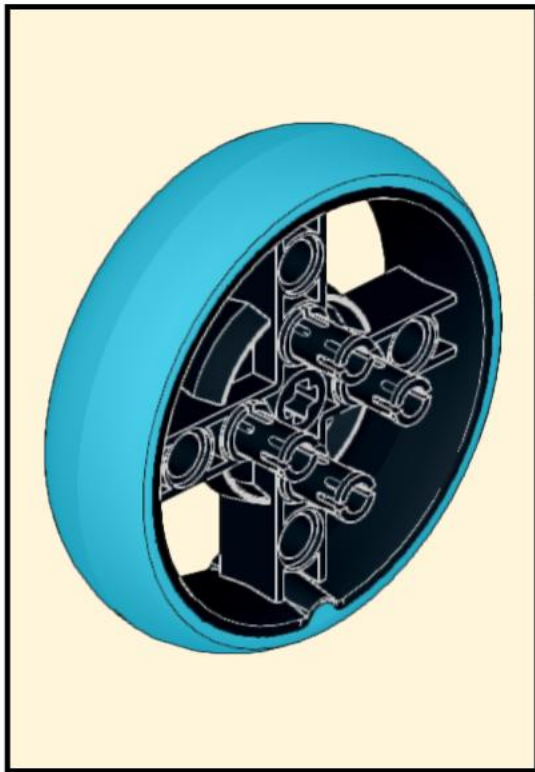
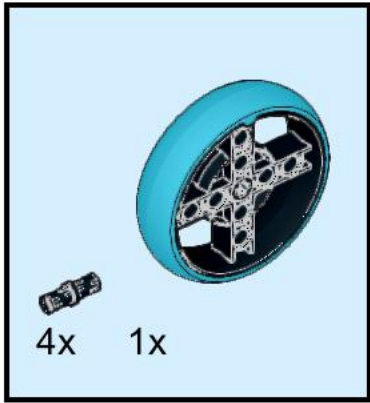

phobricks

5

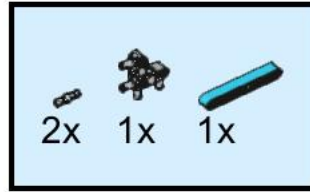
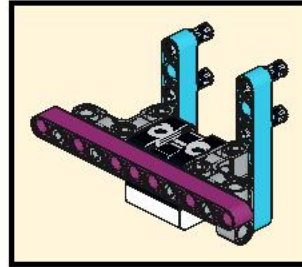
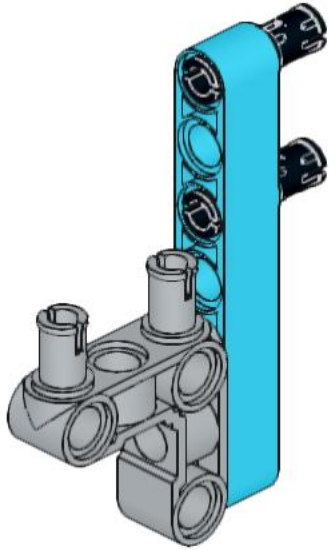

6

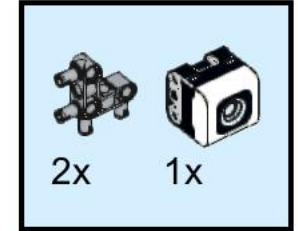
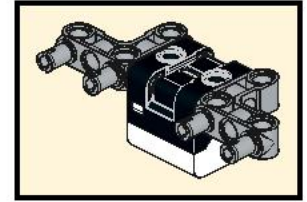
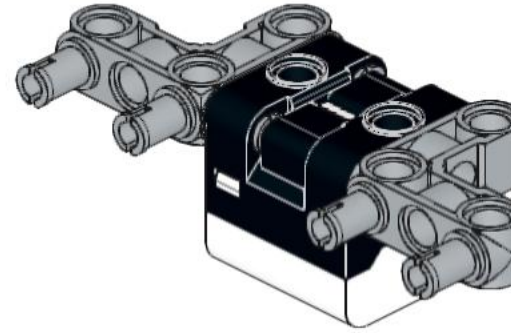

7

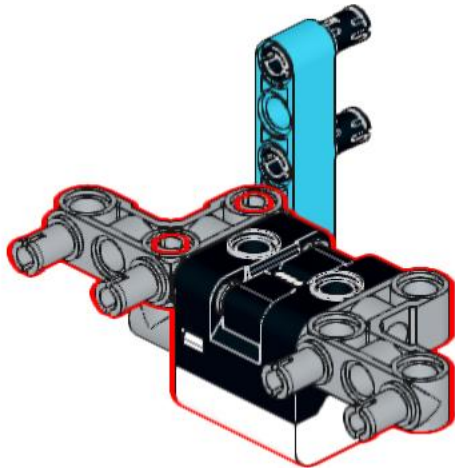

8

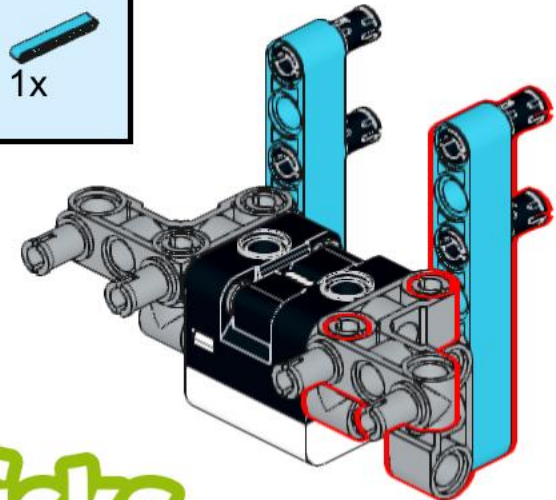
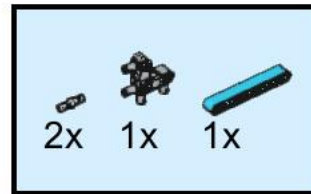

phobricks

9

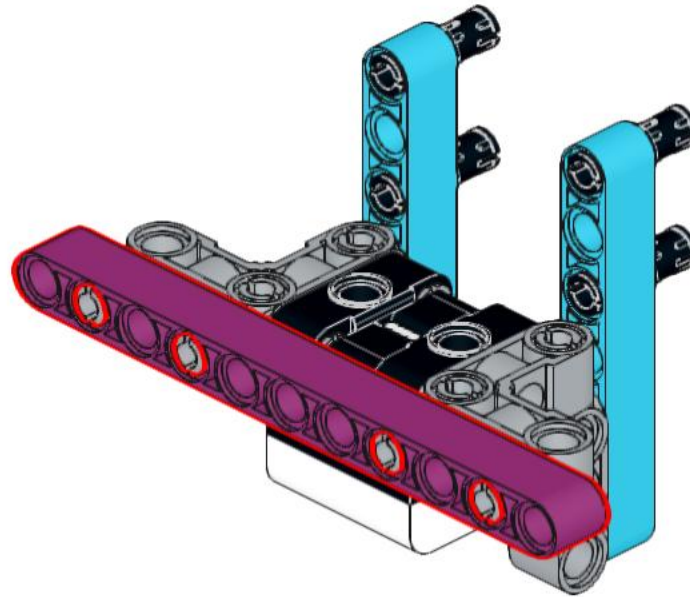
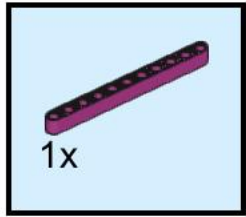

phobricks

10

Kabelführung



unter Hub

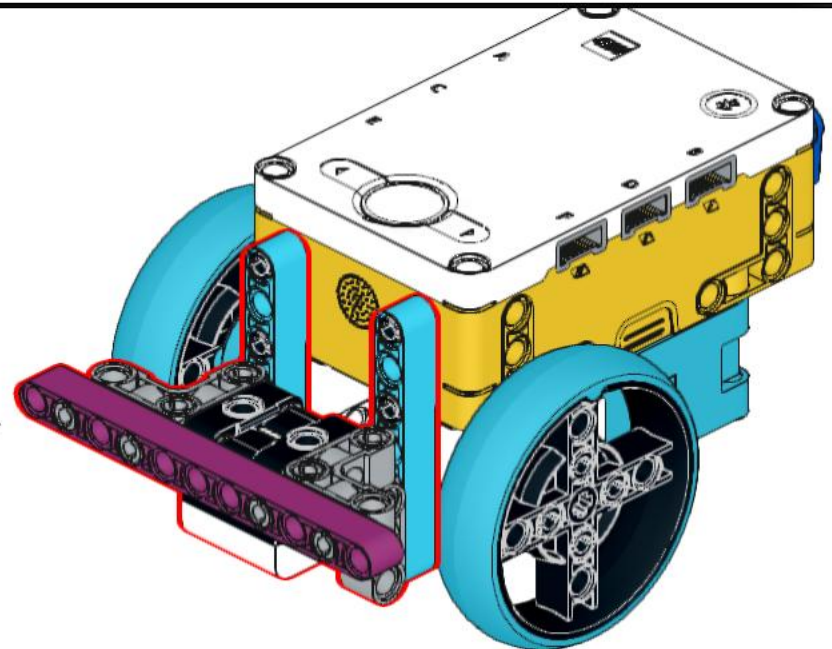

11

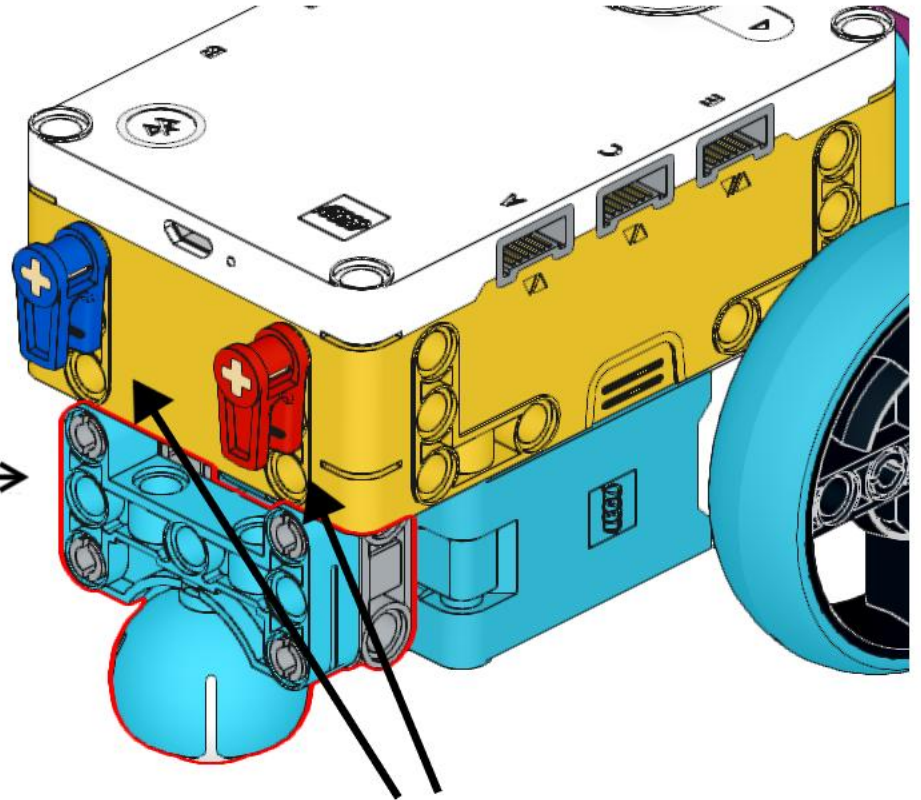
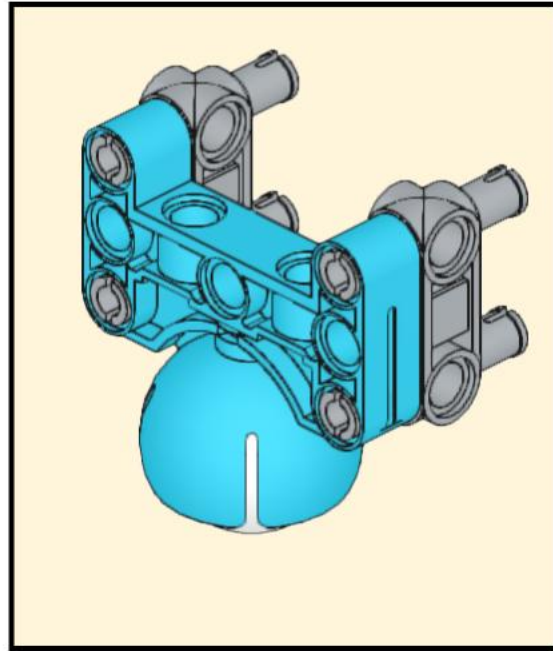
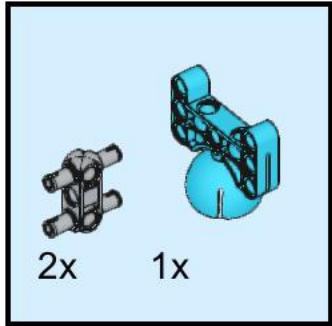

Kabelführung

Farbsensor

Clips für die beiden Motorenkabel

Motor links

Motor rechts

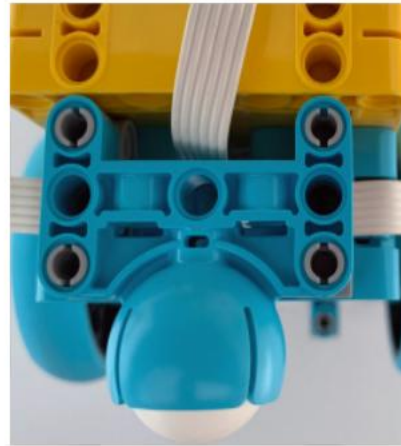

phobricks

Anschlüsse

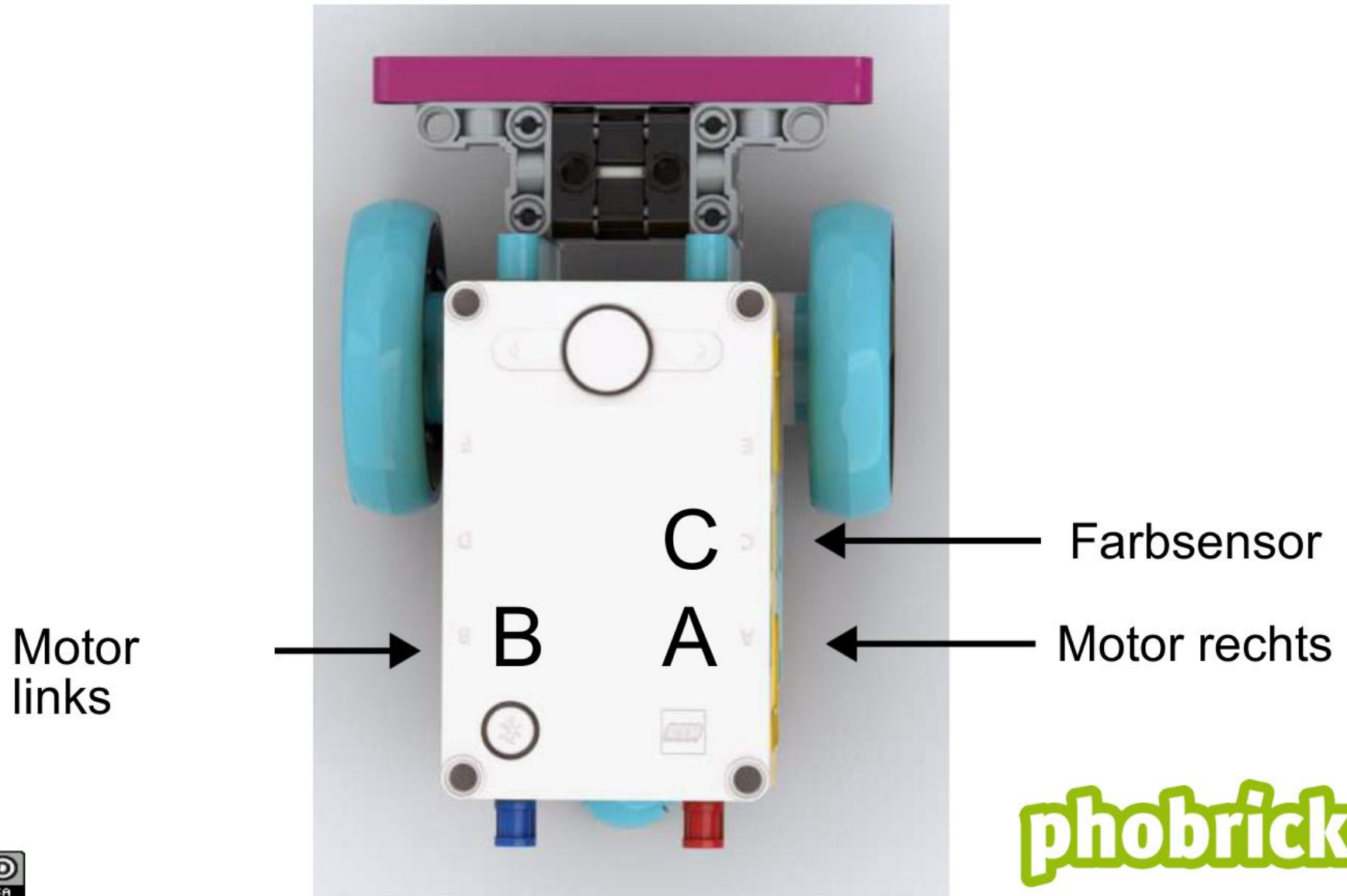

Programm "Bleib in der Arena"

The diagram shows a sequence of programming blocks for a robot:

- wenn das Programm startet** (when the program starts)
- Antriebsmotoren Anschluss B+A zuweisen** (assign drive motors connection B+A)
- Geschwindigkeit auf 50 % einstellen** (set speed to 50%)
- wiederhole fortlaufend** (repeat continuously) loop containing:
 - falls C ist die Farbe [schwarz] ? , dann** (if sensor C is color black, then)
 - 20 cm in folgende Richtung bewegen: [unten]** (move 20 cm in direction down)
 - 10 cm rechts: 70 bewegen** (move 10 cm right: 70)
 - sonst** (otherwise)
 - in folgende Richtung starten geradeaus: 0** (start in direction forward: 0)

phobricks