

SPIKE Prime Basemodell

phobricks

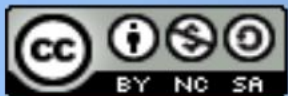
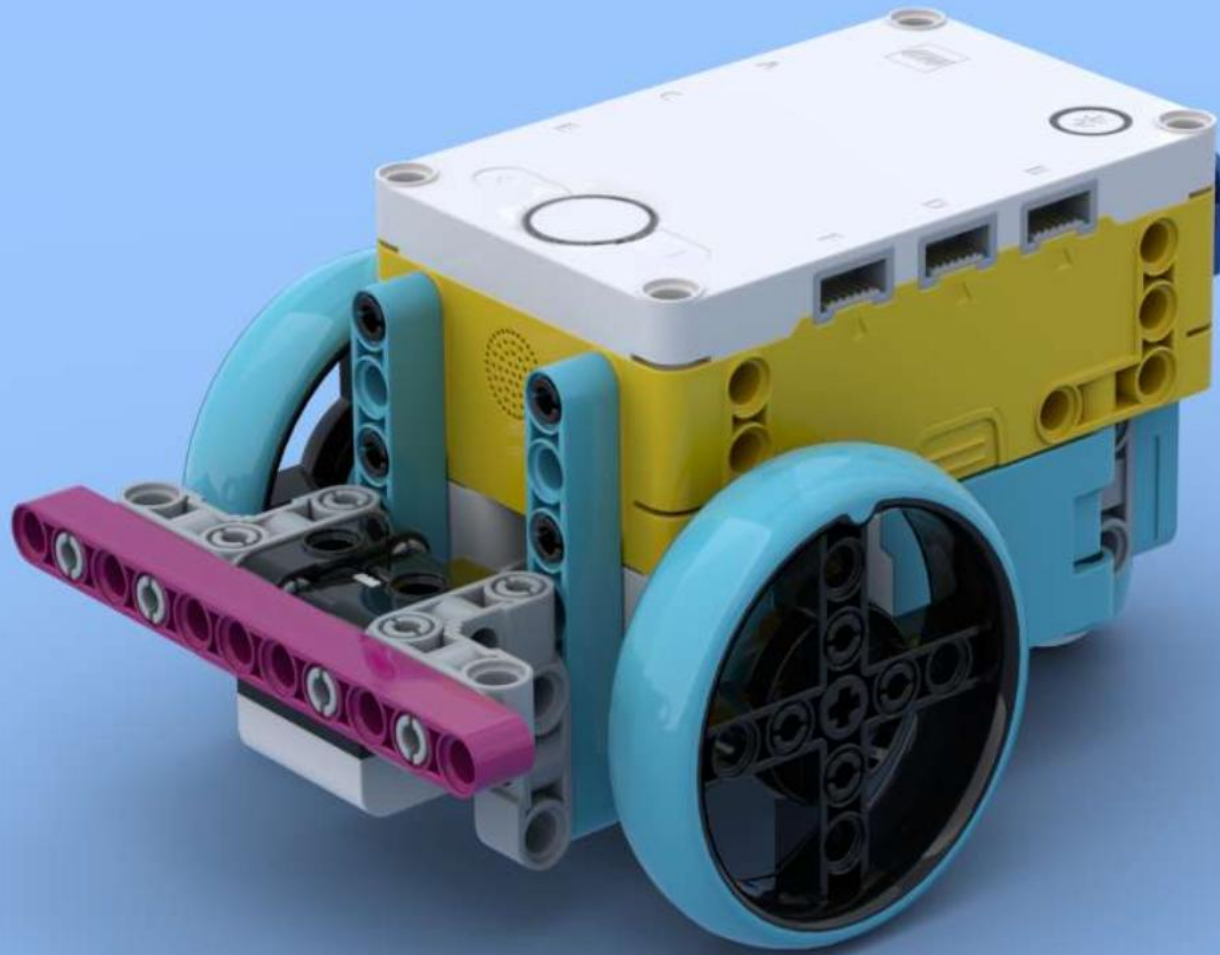

Frank Ellerkamp
<https://phobricks.ch>

1

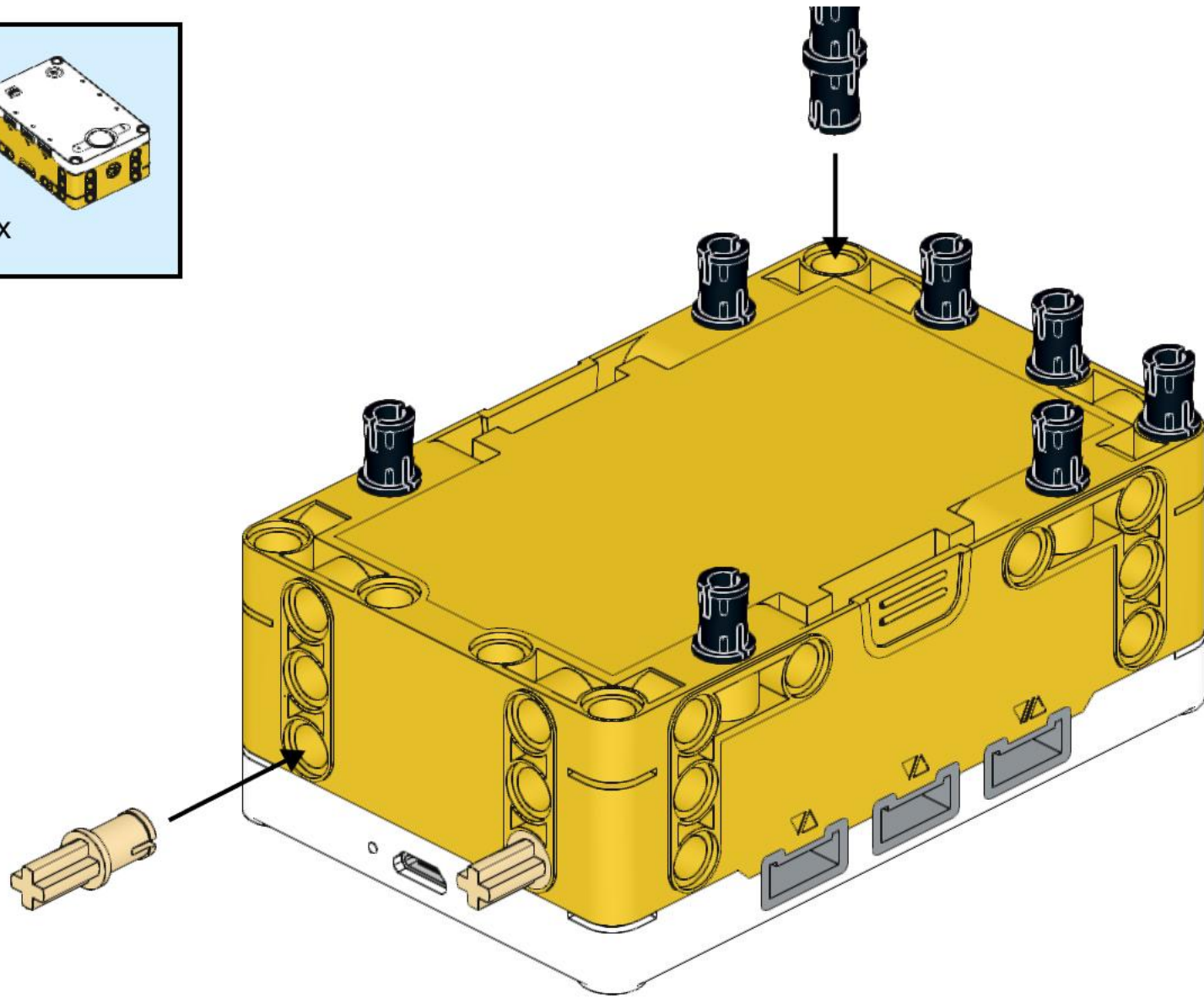
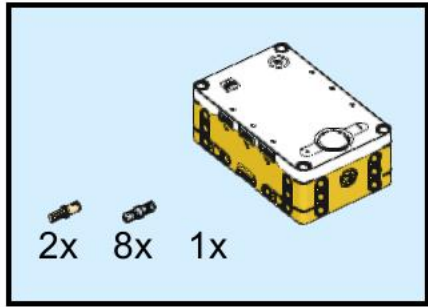

phobricks

2

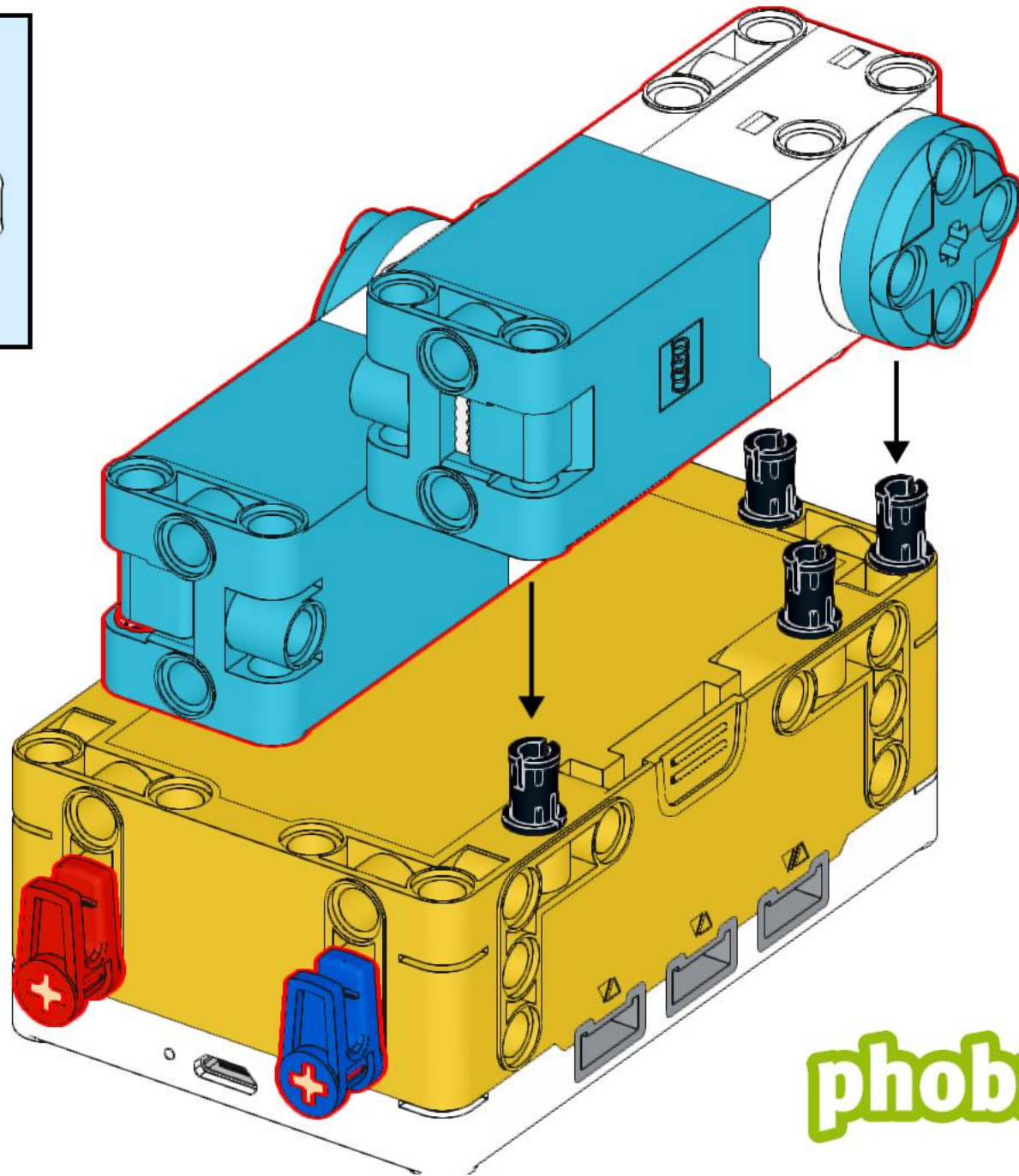
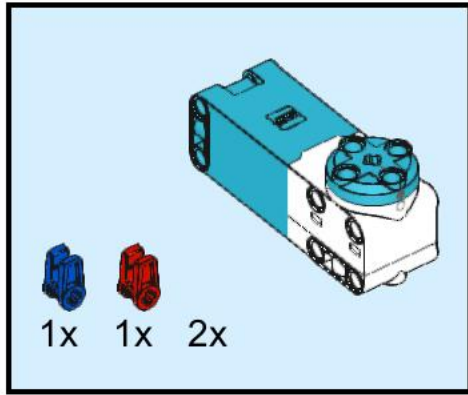

phobricks

3

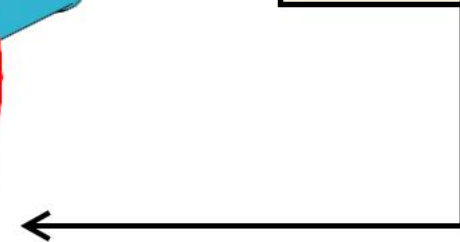
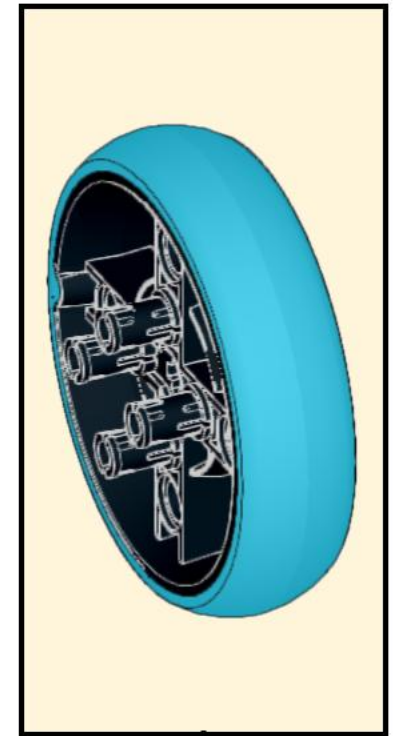
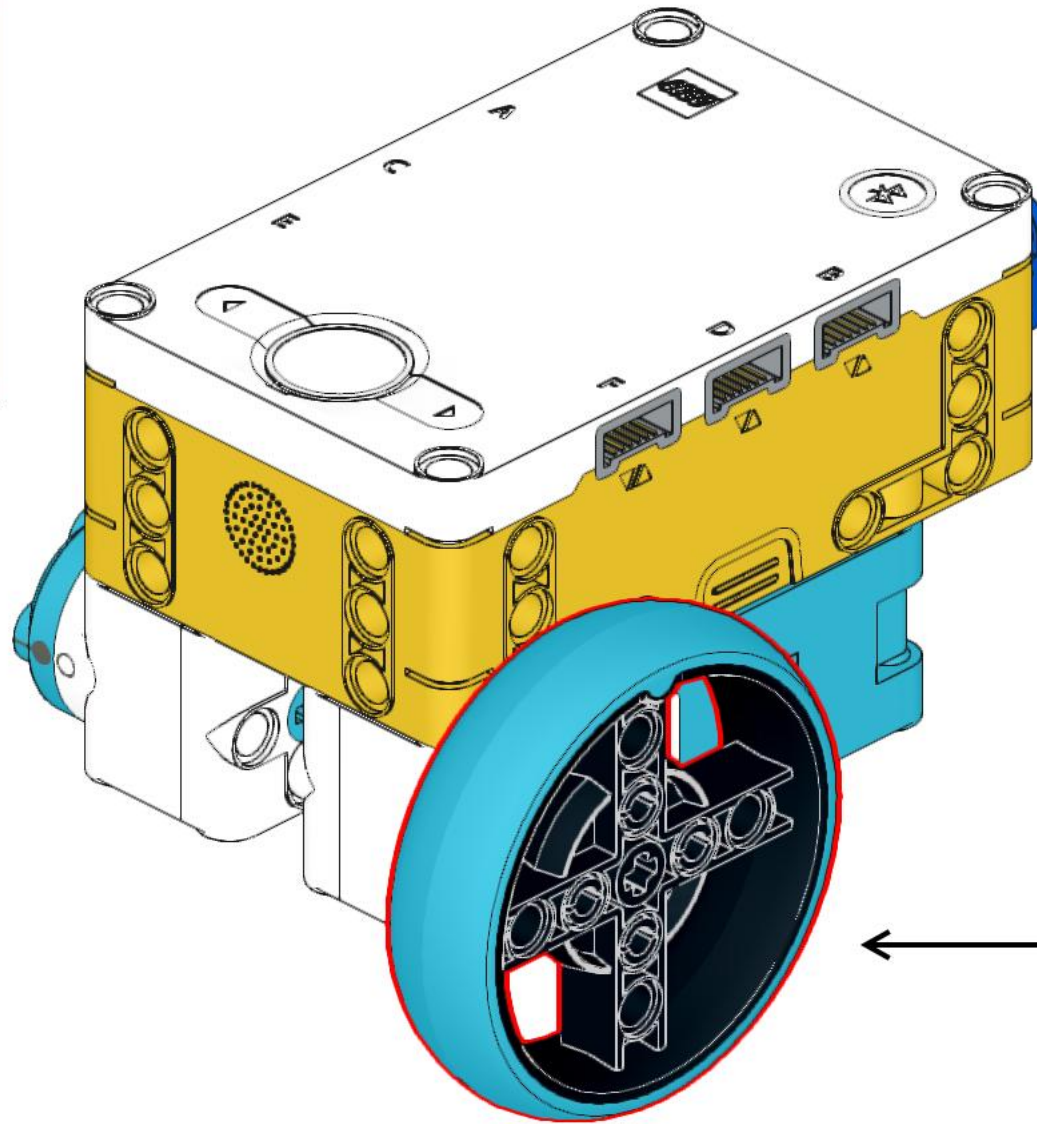
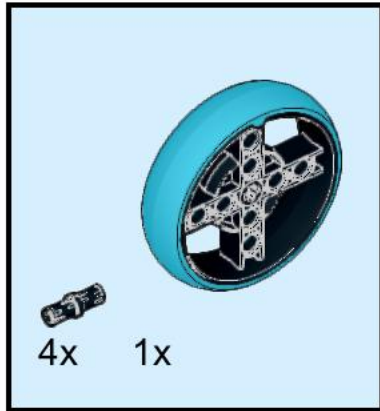

phobricks

4

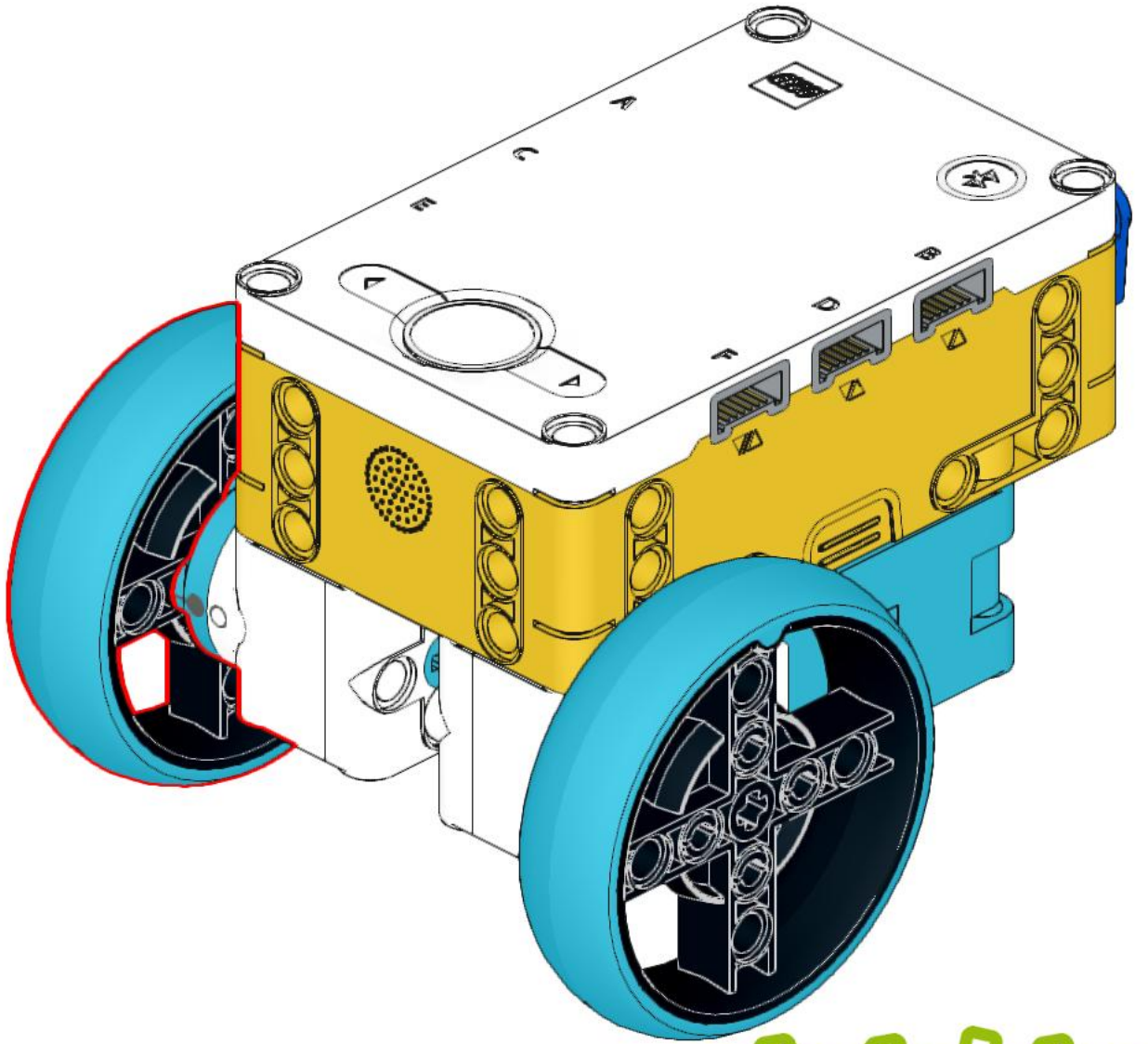
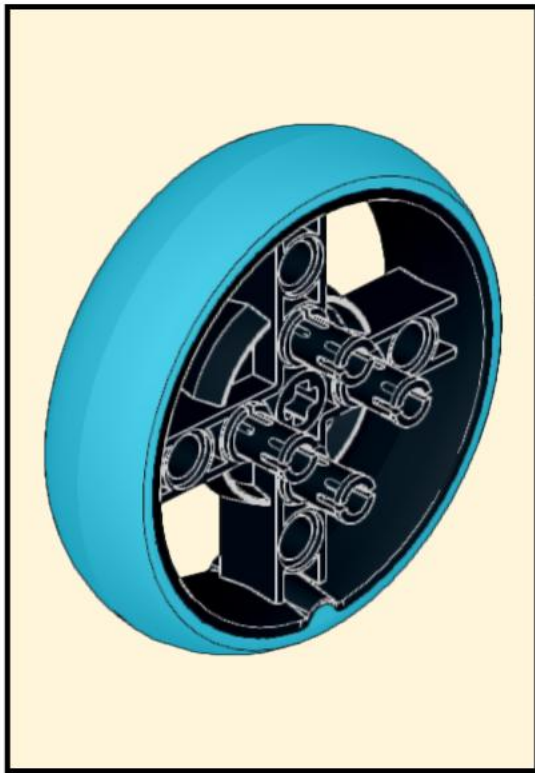
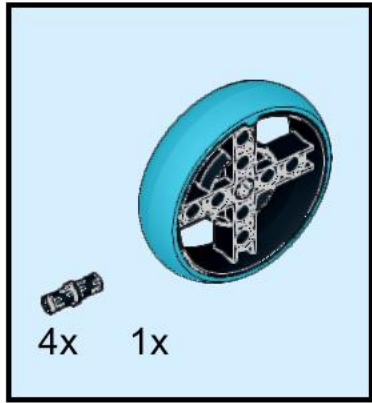

phobricks

5

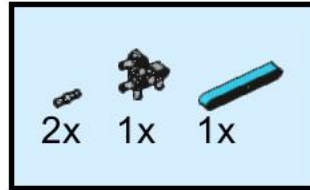
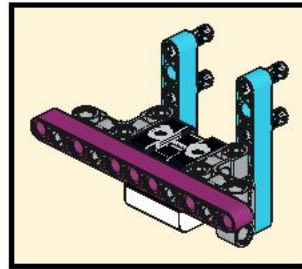
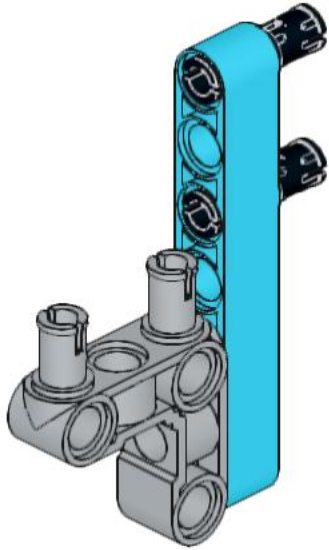

6

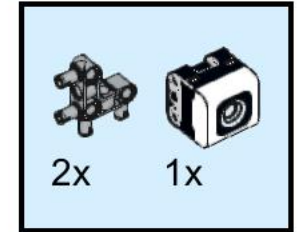
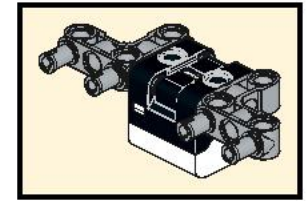
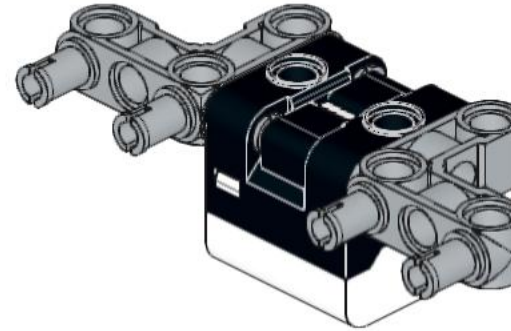

7

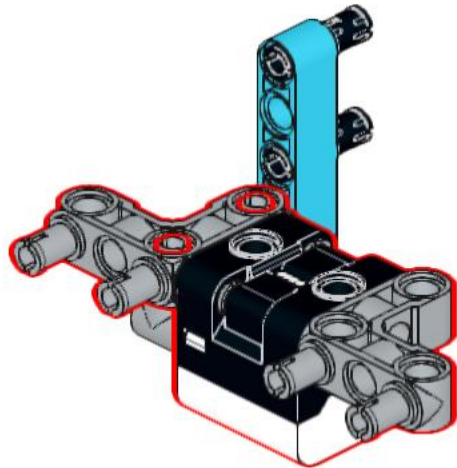

8

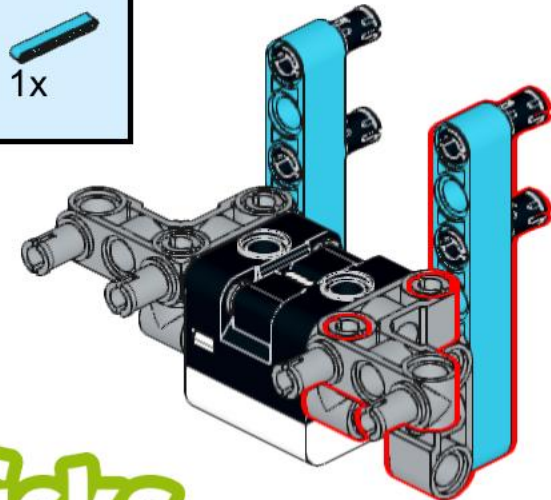
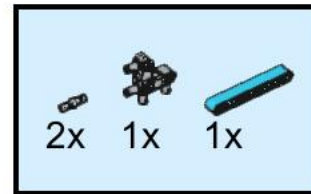

phobricks

9

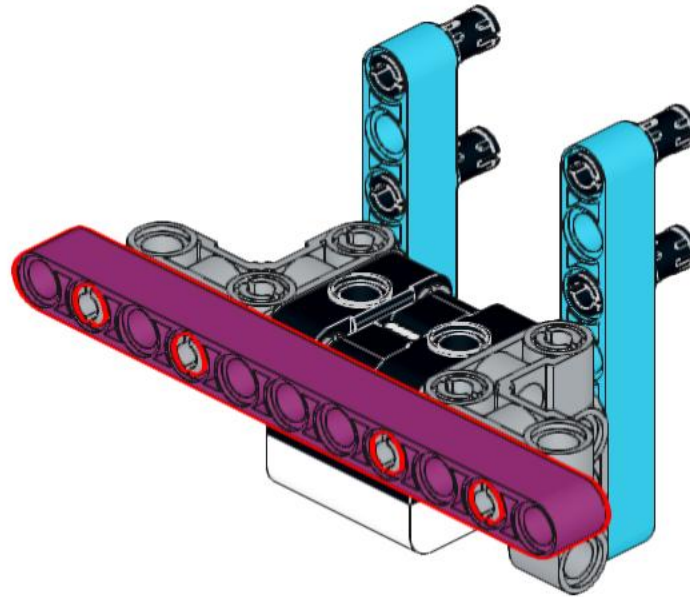
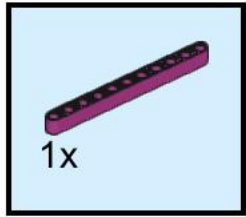

phobricks

10

cable routing



below hub

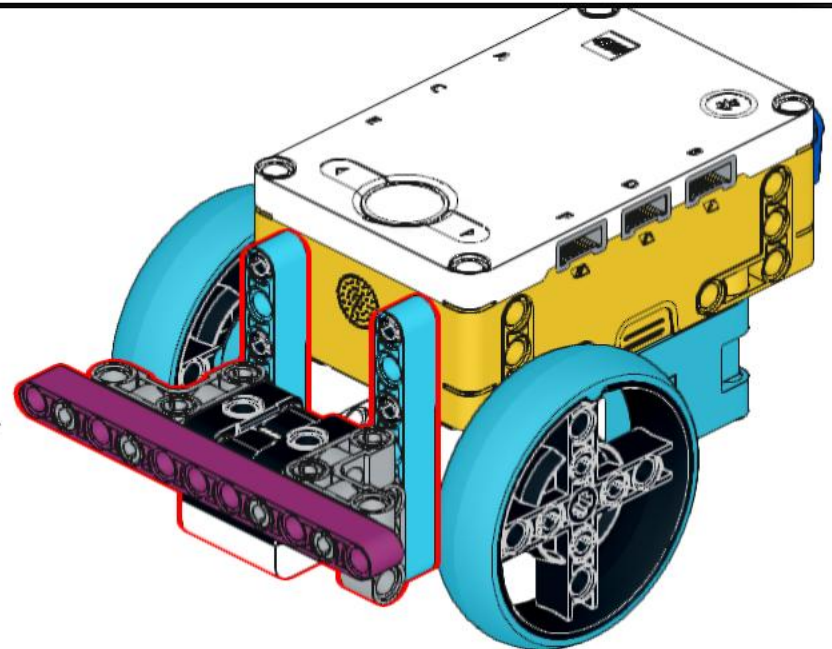

11

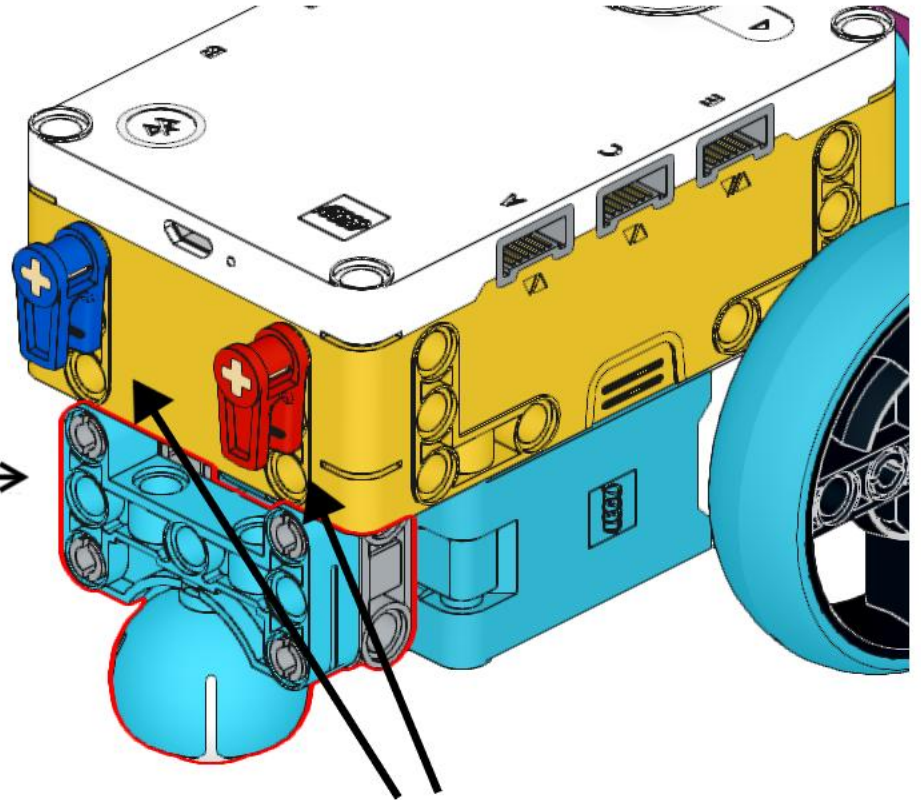
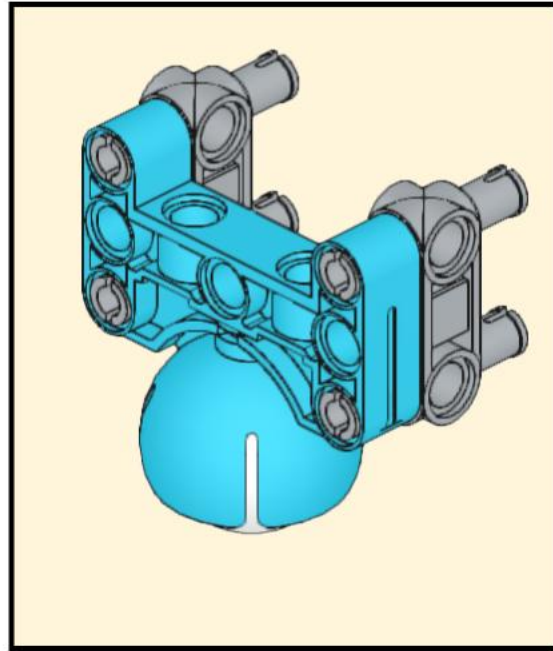
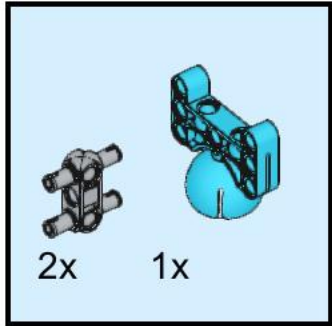

cable routing

colorsensor

clips to be used for the motor cables

left motor

right motor

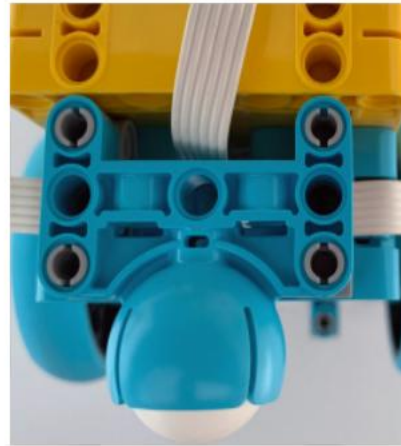

Ports

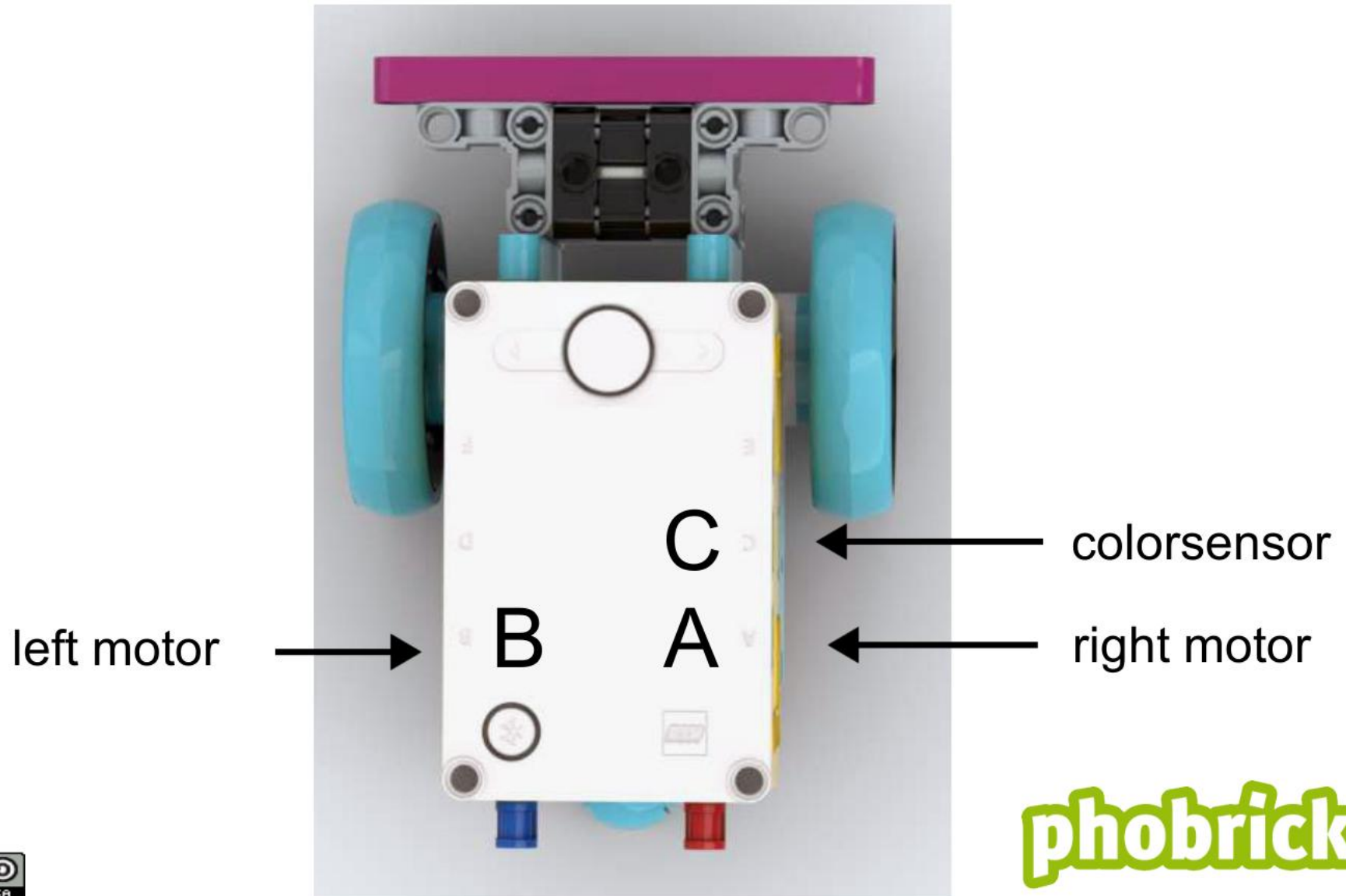

phobricks

block-program "Stay Inside Black Border"

```
when program starts
  set movement motors to B+A
  set movement speed to 50 %
  forever loop
    if C is color black ? then
      move down for 20 cm
      move right: 70 for 10 cm
    else
      start moving straight: 0
```

The image shows a block-based programming script for a robot. It begins with a 'when program starts' block, followed by two motor configuration blocks: 'set movement motors to B+A' and 'set movement speed to 50 %'. A 'forever' loop contains an 'if' block. The 'if' block checks if sensor 'C' is color 'black'. If true, it executes two 'move' blocks: 'move down for 20 cm' and 'move right: 70 for 10 cm'. If false, it executes 'start moving straight: 0'. The 'forever' loop block has a curved arrow at the bottom right indicating it repeats.



phobricks

python-program "Stay Inside Black Border"

```
1 from spike import PrimeHub, ColorSensor, MotorPair
2
3 myHub = PrimeHub()
4 myColorSensorC = ColorSensor('C')
5 myMotorPair = MotorPair('B', 'A')
6
7 while True:
8     color = myColorSensorC.wait_for_new_color()
9     if color == 'black':
10         myMotorPair.move(20, 'cm', 0, -50)
11         myMotorPair.move(10, 'cm', 70, 50)
12     else:
13         myMotorPair.start(0, 50)
```



phobricks